

Truck-mounted concrete pump

BRF/BSF 42.14 H .16 H

Output up to 160 m³/h
Delivery pressure up to 130 bar

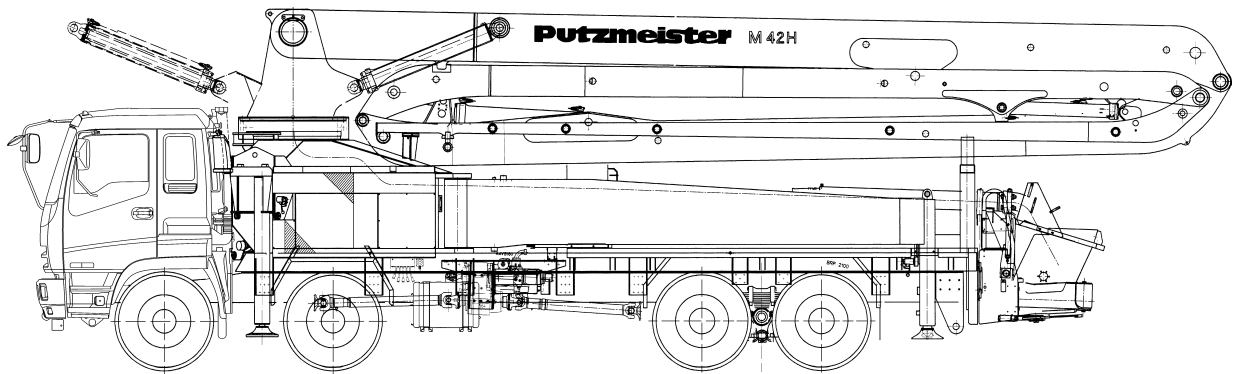
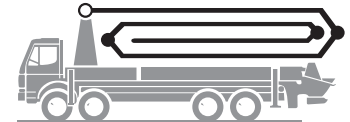

Technical data for concrete pump

	Model	BRF 42.14H	BSF 42.14H	BRF 42.16H	BSF 42.16H
Rod side	Output	140 m ³ /h		160 m ³ /h	
	Delivery pressure	70 bar		85 bar	
Piston side	Output	88 m ³ /h		108 m ³ /h	
	Delivery pressure	112bar		130 bar	
Transfer tube		C transfer tube (R 2002)	S transfer tube (S 2318)	C transfer tube (R 2002)	S transfer tube (S 2318)
Hopper		RC 704 Approx. 600L	RS 907A Approx. 600L	RC 704 Approx. 600L	RS 907A Approx. 600L
Delivery cyl. fl		230 mm			
Stroke of delivery cyl.		2100 mm			
Filling height		approx. 1.35 m			
Control system		Free-Flow Hydraulics (FFH)			

Technical data for boom

Model	Boom M42-4	
Reach height	41.9m	
Horizontal reach	38.0m	
Reach depth max.	29.1m	
Max. Support leg force	Front:	24.5Mp/245kN
	Rear:	23.5Mp/235kN
Unfolding height	10m	
End hose length	4m	
Delivery line	DN 125, max. 85 bar	
Slewing circle	365°	
Number of arms	4	
Folding system	Roll-and-fold(R)	
Hydraulic control	Modul Boom Control (MBC)	
Remote control	Cable remote control	
Support	Front:	Telescoping, diagonally
	Rear:	Swinging

* Dimensions, weight and engine power depend on truck model.

All data maximum theoretical.

Right to make technical amendments and interpretation reserved by Putzmeister.

Reach information diagram, Support, Performance diagram

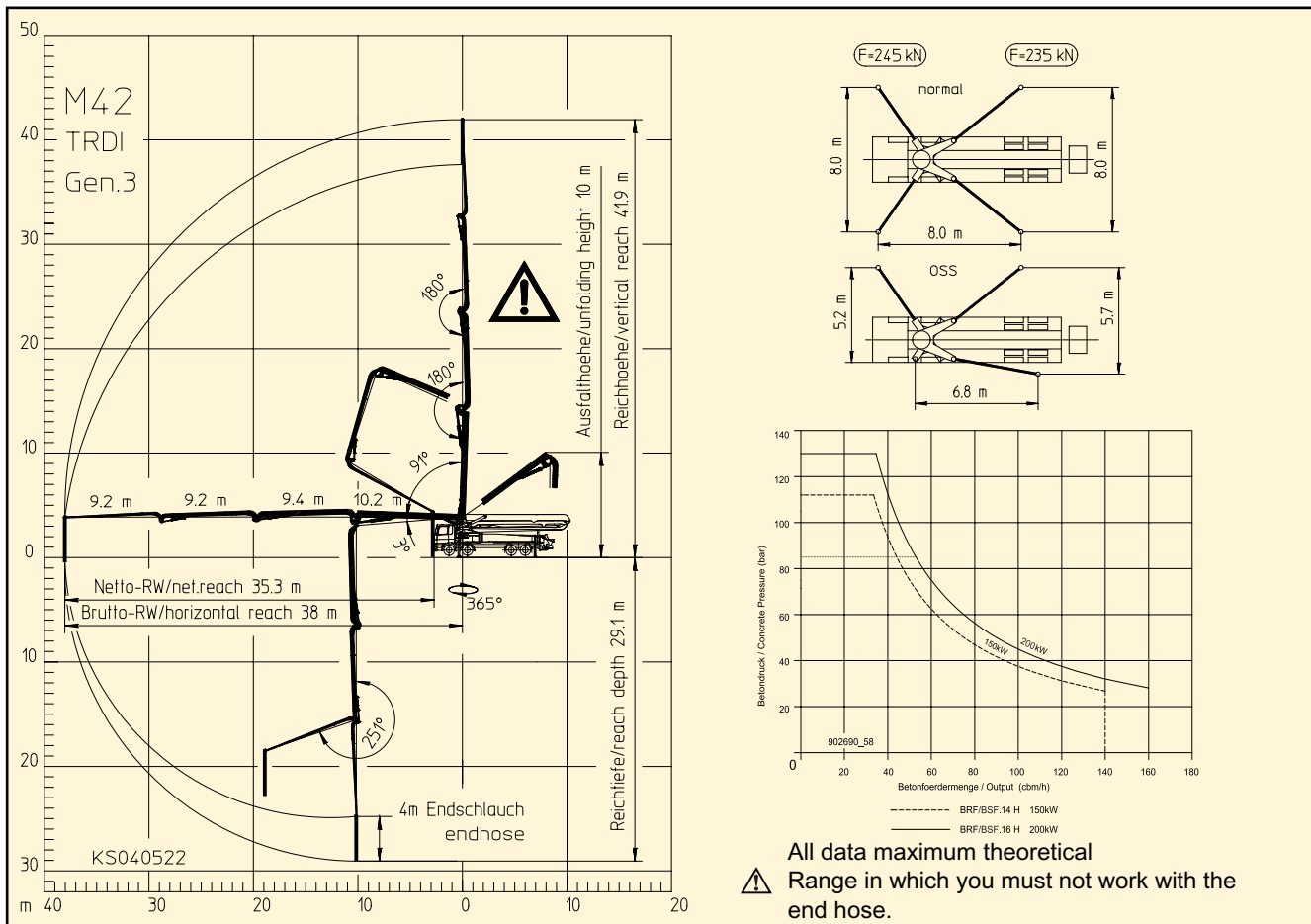

• Standard version / ◦ Optional extras

- Water tank volume approx.700L
- Delivery cylinder Ø230mm
- BRF: RC 704 hopper with trunk R2002
- BSF: RS 907A hopper with S2318N transfer tube
- Support plates 4x in magazine
- MBC
- Delivery line DN 125(5.5"), 133 x 4
- G64 PTO gearbox
- Cable remote control
- Remote control cable 40m
- Tool box
- Spray hose 10m with nozzle
- Painting: Arm assembly RAL 3020, signal red
- Painting: Pump MB 1227, chrome yellow
- Rubber collar for hopper
- Protected cover for plunger cylinder
- S-TUBE 2318 W/90MM SHAFT (S-valve only)
- Water tank left in rear support legs
- Output regulator
- Central grease lubrication hand pump for hopper
- Agitator safety switch off,electrial
- Cleaning port and catching basket
- Side deck (Aluminium)
- OSS one side support
- Central lubrication CP+Boom, electr.
- Radio remote control