

Truck-mounted concrete pump

BSF 46-5.14 H

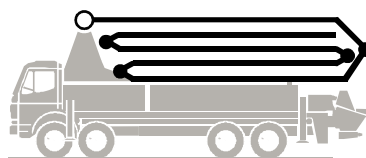

.16 H

.16 H LS

Output up to 160 m³/h
Delivery pressure up to 130 bar

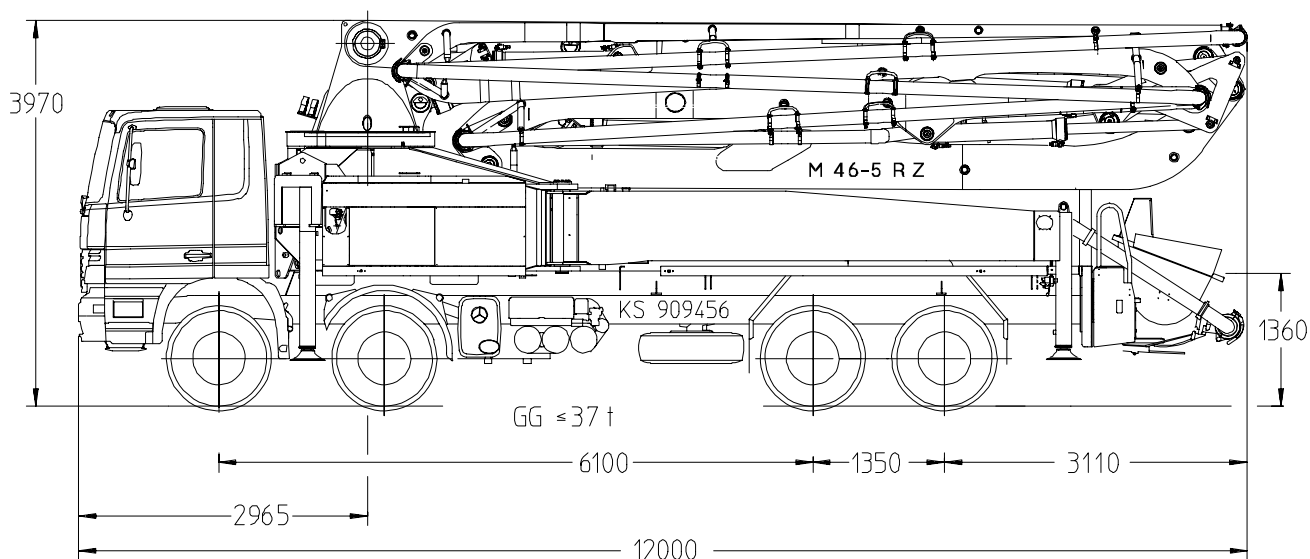

Note: Standard version. Dimensions and weights depend on truck, pump model and equipment.
Dimensions in mm, MB-Actros 4144 as example

Technical Data

Boom M 46-5			
Reach height	m	45.1	
Horizontal reach	gross	m	41.1
	net	m	38.2
Reach depth max.	m	32.2	
Unfolding height	m	9.3	
End hose length	m	4	
Number of arms	5		
Folding system	Roll-Z-folding (RZ)		
Delivery line	DN 125/5.5		

Pump		BSF	.14 H	.16 H	.16 H LS
Rod side	Output	m ³ /h	140	160	-
	Delivery pressure	bar	70	85	-
	Strokes	1/min.	27	31	-
Piston side	Output	m ³ /h	88	108	160
	Delivery pressure	bar	112	130	85
	Strokes	1/min.	17	21	26
Delivery cylinder		∅ mm	230	230	250
Stroke		mm	2100	2100	2100

Delivery line boom max. 85 bar.
All data maximum theoretical.

Reach information diagram, Support, Performance diagram

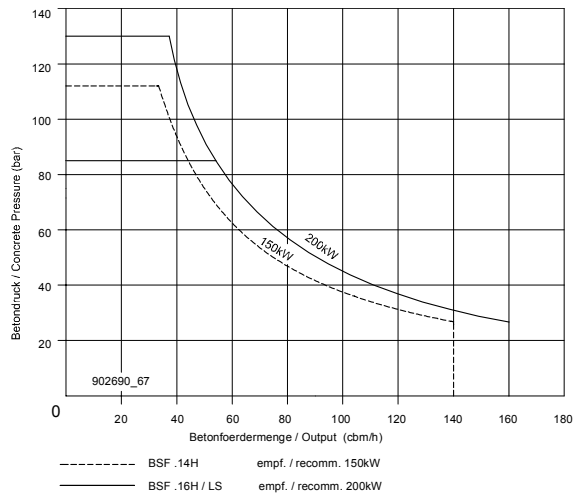
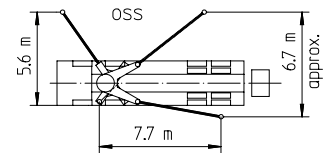
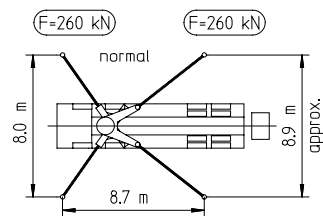
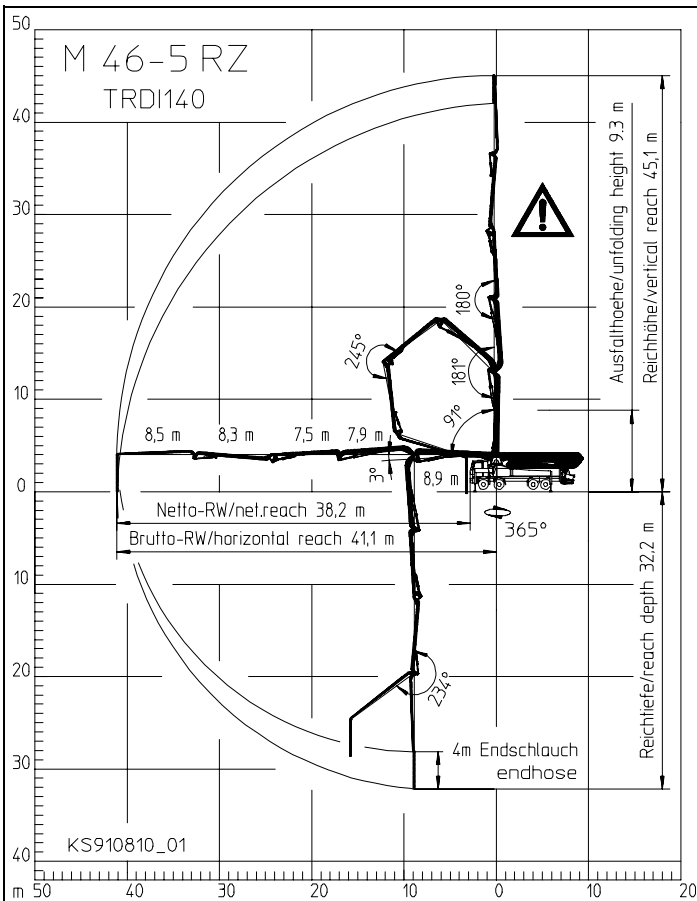

All data maximum theoretical

Range in which you must not work with the end hose.

Delivery scope

	Standard	Options Package *	Options Package Plus
support plates 4x in magazine	●		
flashlights for 4 support legs front and rear	●		
concrete hopper RS 900 with agitator	●		
diagnose interfaces, central for electric and hydraulic	●		
EOC (Ergonic output control)	●		
EPS (Ergonic pump system)	●		
EGD (Ergonic Graphic Display)	●		
radio remote control with display	●		
remote control with 40 m cable	●		
central lubrication strip hopper	●		
rubber collar	●		
painting: arm assembly RAL 3020 signalred	●		
painting: pump MB 1227 chrome yellow	●		
flushing water pump 160 l/min 25 bar	●		
water tank	●		
concrete line DN125/5.5, 133x4	●		
concrete line DN125/5.5, PM 22 twin layer		●	
concrete line DN125/5.5, PM 252 Proline			●

	Standard	Options Package *	Options Package Plus
support plates 4x + timber wood 8x1000 in magazine		●	●
OSS one side support		●	●
traffic permission kit		●	●
splash guard foldable		●	●
lighting in toolbox		●	●
central lubrication hopper, electrical		●	●
horn at the boom		●	●
working search light on boom for hopper illumination			●
spotlights 4x for illumination support area			●
high pressure water pump 100 bar with dry-run protection			●
vibrator, electrical			●
hard metal wear parts kit			●

* recommended in Europe

special: Ergonic Boom Control EBC

Please see quotation for exact serial delivery scope.