

3PD-685-1220 "CAWASA" 3 Ton Pallet Truck

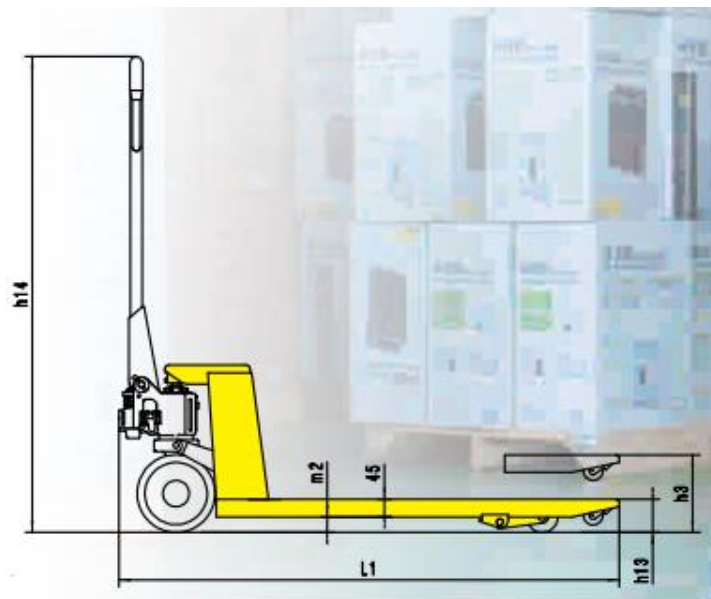
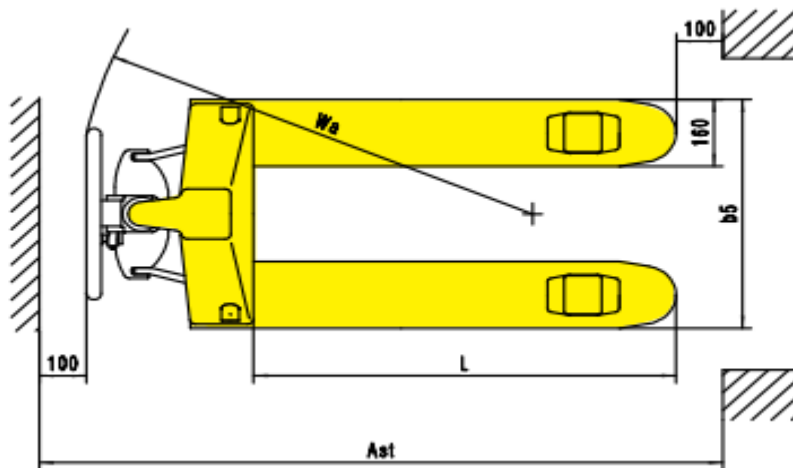

- Most standard and popular model with capacity 2500-3000kgs.
- With Copping Supporting NOG & strengthening ribbing under top triangle cover.
- Complete pump design with reliable leak-proof pump eliminating maintenance and extending the service time.
- 210 steering arc, and small turning radius.
- Fork lowering speed is controllable, operated by hand control and foot pedal.
- Entry/exit roller, more freely travel.
- Equipped with over-load valve, with long service time.
- 3 position hand control-Raise, Lower, Neutral.
- 12 lubrication grease nipples on all movable parts for easy maintenance.
- Adjustable pump cap ensures a long service life.
- Ergonomic large rubber handle with three control lever.

Model		3PD-685-1220
Capacity	Q(kg)	3000
Lowered fork height	H13(MM)	85
Steering Wheel	Mm	ϕ 200
Fork Wheel single	Mm	Φ 80×93
Fork Wheel tandem	Mm	Φ80×70
Max. Lift Height	H3(mm)	200
Total Height	H14(mm)	1603
Overall Length	l1(mm)	1544/1614
Fork Length	s/e/l	1220
Width overall forks	B5(mm)	685
Type of Wheel		PU Double
Ground clearance, centre of wheelbase	m2(mm)	40
Aisle width for pallets 1000x1200 crossways	Ast(mm)	1803
Aisle width for pallets 800x1200 lengthways	Ast(mm)	1803
Turning radius		1336
Weight	Kg	75