

HT28 RTJ O



PERFORMANCE & PRODUCTIVITY

- > Industry leading horizontal outreach of 23.85 m
- > Smooth and precise movements
- > Outstanding RT capacities
- > Dual load 230 - 350 kg (optional)

SAFETY & COMFORT

- > Haulotte Activ'Lighting System for safe loading / unloading in conditions of low visibility (optional)
- > Ultimate control & comfort is engineered to provide superior working-envelope efficiency
- > Rugged boom design
- > Haulotte Activ'Shield Bar (optional)

COST EFFICIENCY

- > Haulotte Activ'Screen (on-board diagnostic)
- > Haulotte Stop Emission System regulates engine run time, reducing fuel consumption, pollution and noise
- > Easy access to all components
- > Modular basket quick and easy to repair



HT28 RTJ O

ROUGH TERRAIN TELESCOPIC BOOMS

TECHNICAL DATA

HT28 RTJ O

Working height	27.9 m
Platform height	25.9 m
Horizontal outreach	23.85 m
Below ground reach	3 m
Lift capacity	230 kg (2 pers.) - option 350 kg
F x G Platform size	2.44 x 0.91 m
A Length - stowed	13.05 m
H Length storage / transport	9.8 m
B Overall width	2.48 m
C Height - stowed	2.85 m
I Height - storage / transport	2.98 m
Vertical jib rotation	133° [- 66° / + 67°]
Jib length	1.83 m
Turntable rotation	360° continuous
Tailswing	150 cm
D Wheelbase	2.8 m
E Ground clearance	48 cm
Tilt	4 °
Drive speed	0.5 - 5 km/h
Gradeability	45 %
Turning radius - outside	6.55 m
Engine	Kubota, 53 kW, Turbo, Stage 5 * NRC: Kubota, 49,2kW, Turbo, Stage 4A
Weight	17 900 kg

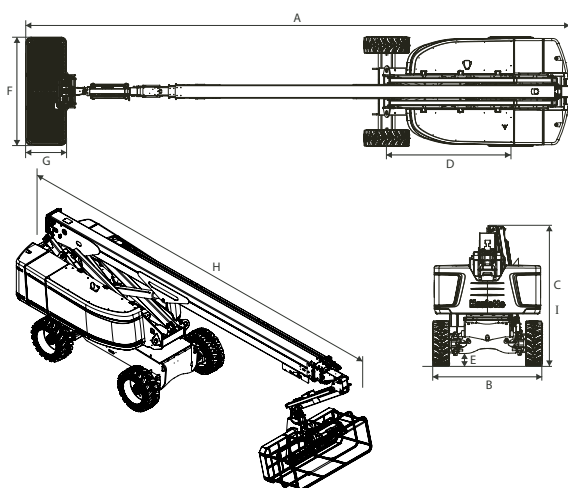

*NRC: Non Regulated Countries

STANDARD EQUIPMENT

- > Haulotte Stop Emission System
- > Haulotte Activ'Screen
- > Universal telematics plug
- > 4 wheel drive / 2 wheel steer
- > Oscillating axle
- > Haulotte smooth & proportional movements
- > Automatic wheel differential lock
- > Upper control box protection cover and tool tray in ultra-rugged composite
- > Large modular basket 2.44 x 0.91 m
- > Drop bar entry gate
- > Basket rotation 180° (± 90)
- > Swing out engine tray for easy maintenance access
- > Sound and light alarm for tilt and load
- > Motion alarm and rotating beacon light alarms

OPTIONS AND ACCESSORIES

- > Haulotte Activ'Lighting System
- > Haulotte Activ'Shield Bar
- > Non-marking tires
- > Dual load capacity 230 - 350 kg (2 persons)
- > 60 km/h wind speed
- > Power to platform (female plug 230 V / 110 V)
- > 1/2 in air line to platform
- > Lateral swing door entry gate
- > Hydraulic generator 3.5 kW or 6.5 kW
- > Hydraulic oil cooler
- > Cold weather package / arctic weather kit
- > Glazier kit
- > Pipe rack kit
- > Motion flashing warning light
- > Battery circuit breaker
- > Battery circuit breaker

