

We build a better future

Robex

145LCR-9

Equipped with Tier 3 Engine



*Photo may include optional equipment.

Pleasure works

An operator, who takes pleasure in his work, does a better job. That is why we at Hyundai Heavy Industries do everything we can to make that happen. We merged operator preference, fast precision and lasting performance into a quality product. Hyundai's 9 series earthmoving equipment simply makes time fly, makes pleasure work!



*Photo may include optional equipment.

Robex 145LCR-9

Machine Walk-Around

Robust Undercarriage

Track chain with urethane seals / Track rail guard / Comfortable bolt-on steps / Large upper roller cut-outs / Grease-type track adjusters.

Engine Technology

Powerful and reliable, fuel efficient Mitsubishi Tier III D04FD-TAA engine.
Electronical controlled, clean and efficient combustion.
Low noise / Auto engine overheat prevention / Anti-restart function.

Hydraulic System Improvements

New patented hydraulic system for maximum controllability / Improved main control valve for higher efficiency and smoother operation / Auto boom vs. swing priority system for maximum speed / Auto power boost for extra power / Improved arm & boom regeneration for higher speed and better efficiency.

Pump Compartment

Powerful and reliable axial piston pumps, designed by Kawasaki.
Compact solenoid block to control: 2 speed travel, power boost, boom priority, arm regeneration and safety lock.

Enhanced Operators' Cabin

Improved Visibility

Enlarged cabin with improved visibility / See-through sunroof for visibility and ventilation.
Large right-side window, for better visibility on foot of boom.
All windows consist of Safety glass.
Roll-up type sun visor for operators' convenience / Reduced front window seam for improved operator view.

Rigid Cabin Construction

New steel tube construction for increased operator safety, higher protection and better durability.
New front window mechanism designed with spring assist.

Improved Seat & Console

Ergonomic joysticks equipped with auxiliary buttons for attachment use.
Standard mechanic suspension with heater or optional air suspension.
New joystick consoles - adjustable in height.
Adjustable arm rests - for optimum comfort.

Advanced 7" Color Cluster

New Color LCD Display with digital gauges for hydraulic oil temperature, coolant temperature and fuel level.
Toggle switch makes it easier to tune your machine and to check diagnostics. A new developed rear-view camera is integrated into the cluster.
3 power modes : Power / Standard / Economy, 3 work modes : Digging / Breaker / Crusher, User mode for saving operators' preferences.
Enhanced self-diagnostic features with remote access through the Hi-Mate system.
One pump flow or two pump flow summation for optional attachment, selectable through the cluster /
Anti-theft system with password entry.
Boom speed and arm regeneration can be adjusted proportionally through the cluster.
Auto power boost in Power-mode - activated through the cluster.
Air conditioning and heater with automatic climate control.
Hi-Mate (Remote Management System) enables machine owners to follow-up machine performance, to verify machine location and to access diagnostic information on a distance through any internet connection.

Preference

An operator, who sets his machine to his needs, takes pleasure in his work. 9 Series respects operator preference with regards to comfort, ease-of-use and controllability. The dashboard cluster with 7 inch screen and toggle switch is the preference nerve centre.



*Photo may include optional equipment.



Spacious Cabin with Excellent Visibility

The spacious cabin is ergonomically designed with low noise levels and high visibility. Special attention was paid to create a clear, open and convenient interior with excellent visibility in all directions. This well balanced operators' environment put the operator in the perfect position to work safely and securely.

Operator Comfort

In a 9 series cabin you can adjust the seat, console and armrests to suit your preferred comfort level. Seat and console can be adjusted in position and height together and independent from each other. A fully automatic, high capacity air conditioning system maintains a constant temperature.



Stressless

Work is stressful enough; your working environment should be stressless. Hyundai's 9 series provides improved cabin interior, additional space and a comfortable seat to minimize the stress of the operator. A powerful climate control system provides the operator with his preferred air temperature. An advanced audio system, AM/FM stereo and MP3 capabilities, plus remote controls is installed to listen to your preferred music favorites. Operators can even call while operating with the hands-free mobile phone feature.



Easy to Use Cluster

The advanced cluster with 7 inch wide color LCD screen and toggle switch allows the operator to select his personal machine preferences. Power and work mode selection, self diagnostics, optional rear-view camera, maintenance check lists, start-up machine security and video functions are integrated into the cluster to make the machine more versatile and the operator more productive.



Precision

An operator, who feels his machine respond smoothly, takes pleasure in his work. 9 Series delivers fast precision by combining smoother hydraulics with wider view and less stress. The innovative Negative hydraulic system combines straightforward technology with superior response.



*Photo may include optional equipment.

Computer Aided Power

The advanced CAPO (Computer Aided Power Optimization) system tunes engine and pump power to optimum levels. Multiple mode selections are implemented for specific applications, maintaining high performance while reducing fuel consumption.

Additional features include auto deceleration and power boost.

The LCD-display monitors engine speed, coolant and hydraulic oil temperature and through the self-diagnostic capability, it displays current error codes. Operators can set their own preferences for boom or swing priority, power mode selection and optional work tools at the touch of a button.

Power Mode

Three unique power modes provide the operator with custom engine power, attachment speed and fuel economy. Power-mode maximizes machine speed and power for maximum productivity. Standard-mode provides a reduced, fixed rpm for optimum performance and improved fuel economy. Economy-mode provides precise flow and engine power based on load conditions, for maximum fuel efficiency and controllability.

Work Mode

Through the different work modes, the operator can select general digging, single-acting attachments like a hydraulic breaker or double-acting attachments like a crusher. Flow settings can be preset through the cluster.

User Mode

Some jobs require more precise machine settings; some operators prefer different machine settings. Using the User-mode, the operator can customize engine speed, pump output, idle speed and other machine settings according to personal preferences.

Hydraulic System Improvements



To achieve optimum precision, Hyundai redesigned the hydraulic system to provide the operator with super fine touch and top level controllability. Spool valves in the control valve are engineered to provide more precise flow to each function with less effort.

Improved hydraulic valves, variable volume piston pumps, fine-touch pilot controls and enhanced travel functions make any operator look like a smooth operator. Newly improved features include arm and boom regeneration, enhanced control valve technology and innovative auto boom and swing priority for best performances in any application.



Auto Boom vs. Swing Priority

This smart function adapts the ideal hydraulic flow balance for the boom and swing operation for your application. The advanced CAPO system monitors the hydraulic operations and adjusts the balance to maximize performance and productivity.

Performance

An operator, who can rely on his machine, takes pleasure in his work. 9 Series stands for lasting performance in strength, speed and reliability. The Auto boom-swing priority results into faster movements and shorter cycle times.



*Photo may include optional equipment.

Track Rail Guard & Adjusters

Durable track rail guards keep tracks in place. Track adjustment is made easy with standard grease cylinder track adjusters and shock absorbing springs.

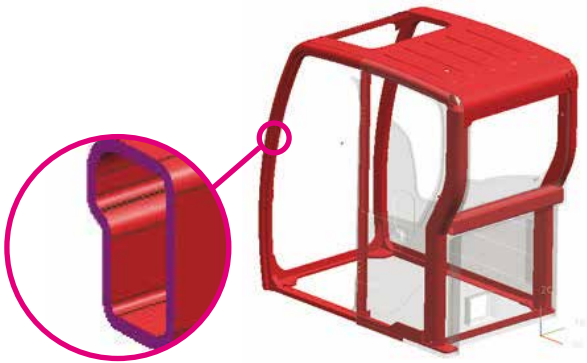

Mitsubishi D04FD-TAA Engine

With 4-cylinders, turbo-charger and intercooler, the Mitsubishi D04FD-TAA engine is built for power, economy and reliability. Electronical controlled fuel injection and diagnostic capabilities add efficiency and serviceability to the engine. This engine meets TIER3 / EU stage IIIa emission regulations.

Structural Strength

The 9 series cabin structure is designed with slimmer but stronger tubing for more safety and better visibility. Low-stress and high-strength steel is welded to form a strong and stable lower frame. Structural durability is analyzed and tested by FEM-analysis (Finite Elements Method) and long-term durability tests.

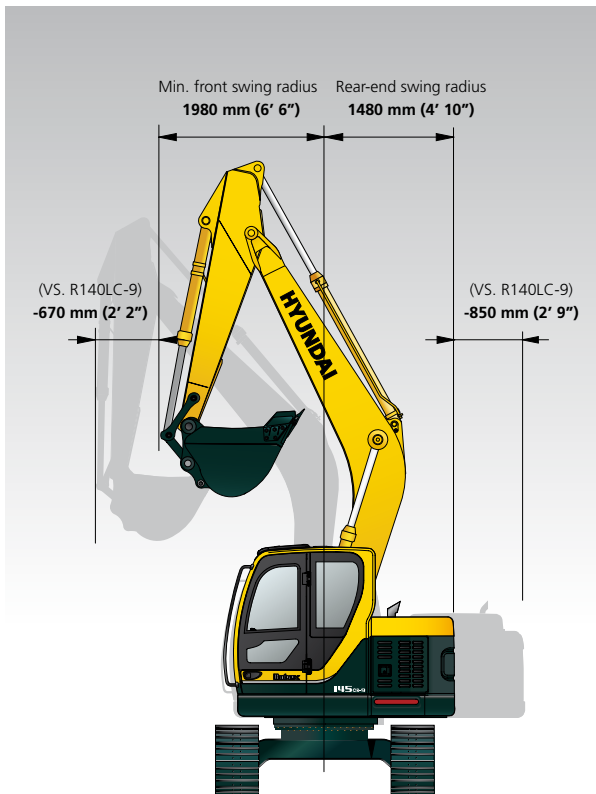

High Performance on Narrow Jobsites

R145LCR-9's reduced tail swing radius allows the operator to work with less worries on narrow jobsites such as road building or urban areas. The Compact radius design provides efficient operation with limited space.

Engine Performance

Every operator knows that there's no substitute for power and durability. The Mitsubishi engine handles the toughest loads and the roughest work conditions combined with maximum fuel economy, better cold starting capability and lower noise level. Plus, the heavy-duty design of the D04FD-TAA engine and related components are offering reliability and durability you can count on every day. Fuel-efficiency and response time are enhanced with the Mitsubishi high pressure common rail fuel system. This fuel system delivers high pressure injection, independent from engine speed, for optimum performance and flexibility at all engine speeds.

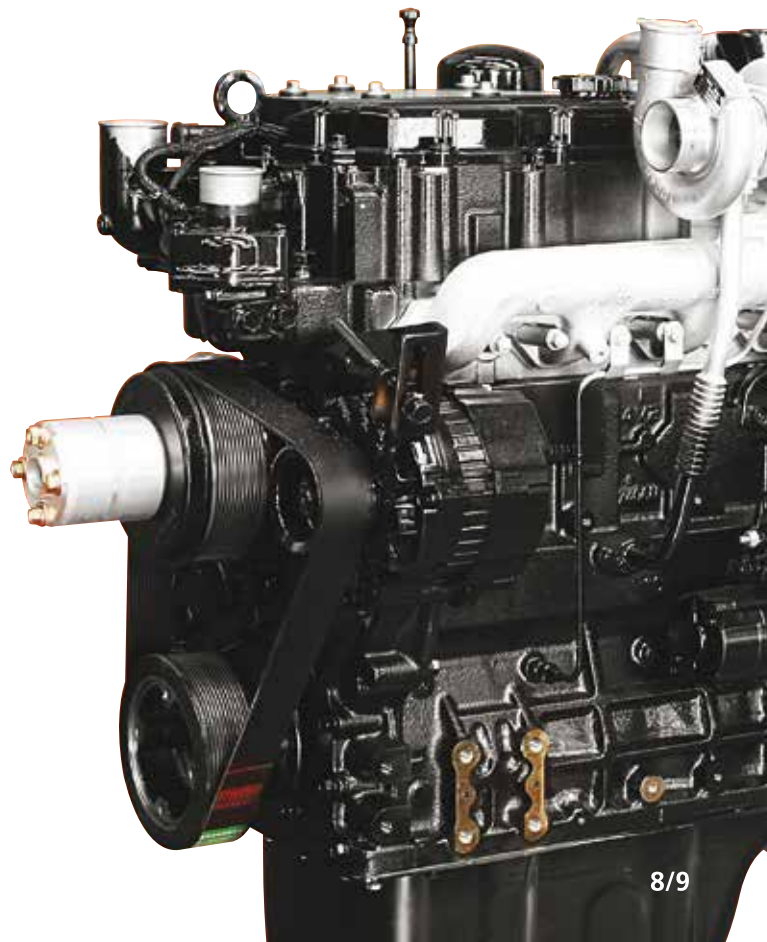

Profitable

An owner, who knows his machine saves money, takes pleasure in owning it. 9 Series excavators contribute to your business as a time, fuel, spare-part and cost saving earthmoving solution. The Remote Management System allows machine owners to track, monitor and manage at a distance.



*Photo may include optional equipment.

Fuel Economy

9 series excavators are developed to do more work with less fuel. Implemented innovations like the variable speed fan clutch, two-stage auto decel system and the new economy mode, are helping to save fuel and reduce the impact on the environment.



Hi-mate (Remote Management System)

Hi-mate, Hyundai's newly developed remote management system, using GPS-satellite technology, provides our customers with the highest level of service and product support. Hi-mate enables machine owners to follow-up machine performance, to verify machine location and to access diagnostic information on a distance through any internet connection.



Easy Access

Access from ground to filters, lube fittings, fuses, drains and machine computer components, combined with wide open compartments makes servicing the 9-series a pleasure for your mechanics.

Extended Life Components

New long-life bushings are designed for extended lube intervals (250 hrs). Wear-resistant polymer shims reduce noise and reduce wear of bushings. Extended-life hydraulic filters last up to 1,000 hrs and new long-life hydraulic oil need only be changed every 5,000 hrs.

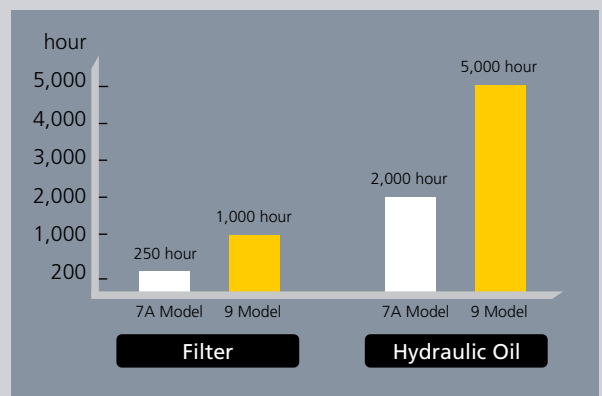
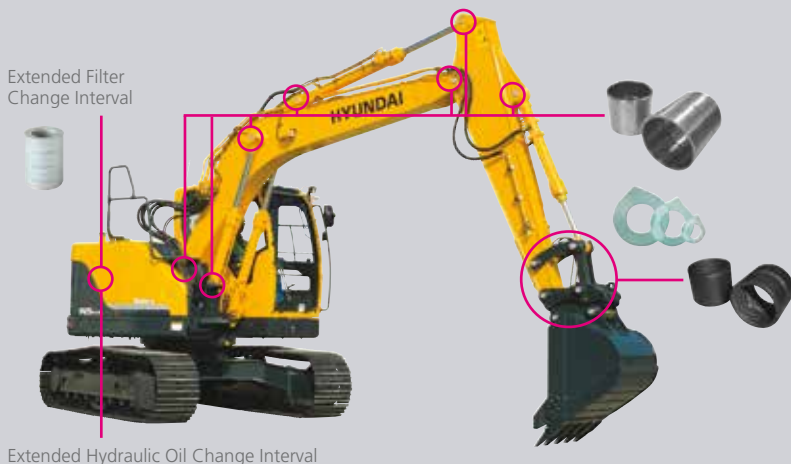

Specifications

ENGINE

MODEL	MITSUBISHI D04FD-TAA		
Type	Water cooled, 4 cycle Diesel, 4-Cylinders in line, direct injection, turbocharged, charged air cooled and low emission		
Rated flywheel horse power	SAE	J1995 (gross)	119 HP (89 kW) / 2,000 rpm
		J1349 (net)	113 HP (85 kW) / 2,000 rpm
	DIN	6271/1 (gross)	121 PS (89 kW) / 2,000 rpm
		6271/1 (net)	115 PS (85 kW) / 2,000 rpm
Max. torque	45.4 kgf.m (328 lbf.ft) / 1,700 rpm		
Bore x stroke	102 x 130 mm (4.0" x 5.1")		
Piston displacement	4,250cc (260 in ³)		
Batteries	2 X 12V X 80AH		
Starting motor	24V - 5.0 kW		
Alternator	24V - 50 Amp		

HYDRAULIC SYSTEM

MAIN PUMP	
Type	Two variable displacement piston pumps
Max. flow	2 X 130 ℓ/min (34.3 US gpm / 28.6 UK gpm)
Sub-pump for pilot circuit	Gear pump
Cross-sensing and fuel saving pump system	
HYDRAULIC MOTORS	
Travel	Two speed axial piston motor with brake valve and parking brake
Swing	Axial piston motor with automatic brake

RELIEF VALVE SETTING	
Implement circuits	350 kgf/cm ² (4,980 psi)
Travel	350 kgf/cm ² (4,980 psi)
Power boost (boom, arm, bucket)	380 kgf/cm ² (5,410 psi)
Swing circuit	285 kgf/cm ² (4,050 psi)
Pilot circuit	40 kgf/cm ² (570 psi)
Service valve	Installed

HYDRAULIC CYLINDERS	
No. of cylinder-bore x stroke	Boom : 105 X 1,105 mm (4.1" X 43.5")
	Arm : 115 X 1,138 mm (4.5" X 44.8")
	Bucket : 100 X 840 mm (3.9" X 33.1")
	Blade : 100 X 260 mm (3.9" X 10.2")

DRIVES & BRAKES

Drive method	Fully hydrostatic type
Drive motor	Axial piston motor, in-shoe design
Reduction system	Planetary reduction gear
Max. drawbar pull	13,300 kgf (29,321 lbf)
Max. travel speed (high) / (low)	5.5 km/hr (3.4 mph) / 3.2 km/hr (2.0 mph)
Gradeability	30° (58 %)
Parking brake	Multi wet disc

CONTROL

Pilot pressure operated joysticks and pedals with detachable lever provide almost effortless and fatigueless operation.

Pilot control	Two joysticks with one safety lever (LH): Swing and arm, (RH): Boom and bucket (ISO)
Traveling and steering	Two levers with pedals
Engine throttle	Electric, Dial type

SWING SYSTEM

Swing motor	Axial piston motor
Swing reduction	Planetary gear reduction
Swing circuit lubrication	Grease-bathed
Swing brake	Multi wet disc
Swing speed	12 rpm

COOLANT & LUBRICANT CAPACITY

Refilling	liter	US gal	UK gal
Fuel tank	232	61.3	51.0
Engine coolant	14.5	3.8	3.2
Engine oil	17.5	4.6	3.8
Swing device - gear oil	2.5	0.7	0.5
Final drive (each) - gear oil	3.6	1.0	0.8
Hydraulic system (including tank)	180	47.6	39.6
Hydraulic tank	96	25.4	21.1

UNDERCARRIAGE

The X-leg type center frame is integrally welded with reinforced box-section track frames. The undercarriage includes lubricated rollers, idlers, track adjusters with shock absorbing springs and sprockets, and a track chain with double or triple grouser shoes.

Center frame	X - leg type	
Track frame	Pentagonal box type	
No. of shoes on each side	R145LCR-9	47EA
No. of carrier rollers on each side		2 EA
No. of track rollers on each side		7 EA
No. of rail guards on each side		2 EA

OPERATING WEIGHT (APPROXIMATE)

Operating weight, including 4,600 mm (15' 1") boom; 2,500 mm (8' 2") arm; SAE heaped 0.52m³ (0.68 yd³) bucket, lubricant, coolant, full fuel tank, full hydraulic tank, and all standard equipments.

MAJOR COMPONENT WEIGHT	
Upperstructure	6,950 kg (15,320 lb)
Counterweight	2,800 kg (6,170 lb)
4.6 m (15' 1") mono boom (with arm cylinder)	1,030 kg (2,270 lb)

OPERATING WEIGHT			
Shoes		Operating weight	Ground pressure
Type	Width mm (in)	kg (lb)	kgf/cm ² (psi)
Triple grouser	500 (20")	R145LCR-9	14,785 (32,600) 0.47 (6.68)
		R145LCR-9 (Dozer type)	15,585 (34,360) 0.49 (6.97)
	600 (24")	R145LCR-9	14,980 (33,020) 0.40 (5.69)
		R145LCR-9 (Dozer type)	15,800 (34,830) 0.42 (5.97)
	700 (28")	R145LCR-9	15,215 (33,540) 0.34 (4.83)
		R145LCR-9 (Dozer type)	16,035 (35,350) 0.36 (5.12)

BUCKETS

All buckets are welded with high-strength steel

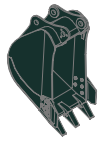

0.23 (0.30)

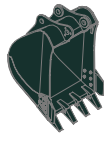

0.40 (0.52)
0.46 (0.60)



0.52 (0.68)
0.58 (0.76)



0.65 (0.85)

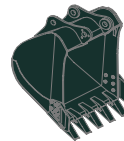

0.71 (0.93)



● 0.45 (0.59)

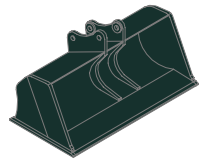

★ 0.55 (0.72)

SAE heaped m³ (yd³)

Capacity m ³ (yd ³)		Width mm (in)		Weight kg (lb)	Recommendation m (ft.in)			
SAE heaped	CECE heaped	Without side cutters	With side cutters		4.60 (15' 1") Boom			
					1.90 (6' 3") Arm	2.10 (6' 11") Arm	2.50 (8' 2") Arm	3.00 (9' 10") Arm
0.23 (0.30)	0.20 (0.26)	520 (20.5)	620 (24.4)	335 (740)	●	●	●	■
0.40 (0.52)	0.35 (0.46)	760 (29.9)	860 (33.9)	410 (900)	●	●	●	■
0.46 (0.60)	0.40 (0.52)	850 (33.5)	950 (37.4)	435 (960)	●	●	●	▲
0.52 (0.68)	0.45 (0.59)	935 (36.8)	1,035 (40.8)	460 (1,010)	●	●	●	-
0.58 (0.76)	0.50 (0.65)	1,030 (40.6)	1,130 (44.5)	480 (1,060)	●	●	■	-
0.65 (0.85)	0.55 (0.72)	1,110 (43.7)	1,210 (47.6)	500 (1,100)	■	■	▲	-
0.71 (0.93)	0.60 (0.78)	1,205 (47.4)	-	540 (1,190)	▲	▲	-	-
● 0.45 (0.59)	0.40 (0.52)	1,520 (59.8)	-	410 (900)	●	●	■	-
★ 0.55 (0.72)	0.45 (0.59)	1,800 (70.9)	-	585 (1,290)	■	▲	▲	-

● Ditch cleaning bucket

★ Slope finishing bucket

● Applicable for materials with density of 2,000 kg/m³ (3,370 lb/yd³) or less

■ Applicable for materials with density of 1,600 kg/m³ (2,700 lb/yd³) or less

▲ Applicable for materials with density of 1,100 kg/m³ (1,850 lb/yd³) or less

ATTACHMENT

Booms and arms are welded, a low-stress, full-box section design. 4.60 m (15' 1") boom and 1.90 m (6' 3"); 2.10 m (6' 11"); 2.50 m (8' 2"); 3.00 m (9' 10") arms are available.

DIGGING FORCE

Boom	Length	mm (ft.in)	4,600 (15' 1")				Remarks
	Weight	kg (lb)	1,030 (2,270)				
Arm	Length	mm (ft.in)	1,900 (6' 3")	2,100 (6' 11")	2,500 (8' 2")	3,000 (9' 10")	[]: Power Boost
	Weight	kg (lb)	560 (1,230)	580 (1,280)	610 (1,340)	670 (1,480)	
Bucket digging force	SAE	kN	87.3 [94.8]	87.3 [94.8]	87.3 [94.8]	87.3 [94.8]	
		kgf	8,900 [9,660]	8,900 [9,660]	8,900 [9,660]	8,900 [9,660]	
		lbf	19,620 [21,300]	19,620 [21,300]	19,620 [21,300]	19,620 [21,300]	
	ISO	kN	102 [110.8]	102 [110.8]	102 [110.8]	102 [110.8]	
		kgf	10,400 [11,290]	10,400 [11,290]	10,400 [11,290]	10,400 [11,290]	
		lbf	22,930 [24,890]	22,930 [24,890]	22,930 [24,890]	22,930 [24,890]	
Arm crowd force	SAE	kN	76.5 [83.1]	73.6 [79.9]	62.8 [68.2]	55.9 [60.7]	
		kgf	7,800 [8,470]	7,500 [8,140]	6,400 [6,950]	5,700 [6,190]	
		lbf	17,200 [18,670]	16,530 [17,950]	14,110 [15,320]	12,570 [13,640]	
	ISO	kN	80.4 [87.3]	77.5 [84.1]	65.7 [71.4]	57.9 [62.8]	
		kgf	8,200 [8,900]	7,900 [8,580]	6,700 [7,270]	5,900 [6,410]	
		lbf	18,080 [19,630]	17,420 [18,910]	14,770 [16,040]	13,010 [14,120]	

Note: Boom weight includes arm cylinder, piping, and pin

Arm weight includes bucket cylinder, linkage, and pin

Dimensions & Working Ranges

DIMENSIONS R145LCR-9

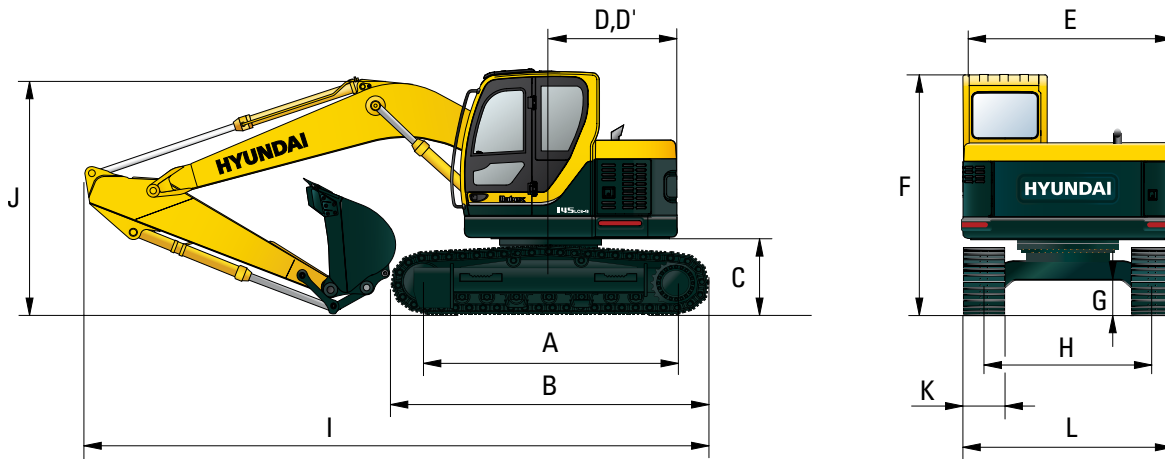

mm (ft · in)

mm (ft · in)

A Tumbler distance	3,090 (10' 2")	Boom length	4,600 (15' 1")			
B Overall length of crawler	3,820 (12' 6")	Arm length	1,900 (6' 3")	2,100 (6' 11")	2,500 (8' 2")	3,000 (9' 10")
C Ground clearance of counterweight	930 (3' 1")	I Overall length	7,380 (24' 3")	7,400 (24' 3")	7,360 (24' 2")	7,300 (23' 11")
D Tail swing radius	1,480 (4' 10")	J Overall height of boom	2,630 (8' 8")	2,710 (8' 11")	2,860 (9' 5")	3,210 (10' 6")
D' Rear-end length	1,480 (4' 10")	K Track shoe width	500 (20")	600 (24")	700 (28")	
E Overall width of upperstructure	2,500 (8' 2")	L Overall width	2,500 (8' 2")	2,600 (8' 6")	2,700 (8' 10")	
F Overall height of cab	2,900 (9' 6")					
G Min. ground clearance	440 (1' 5")					
H Track gauge	2,000 (6' 7")					

WORKING RANGE R145LCR-9

mm (ft · in)

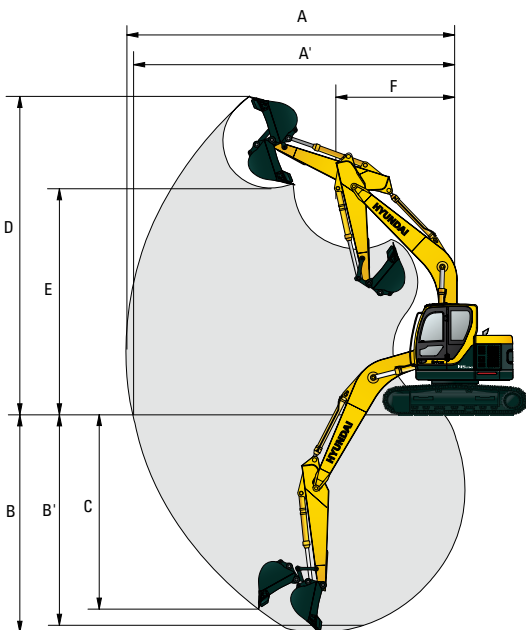

Boom length	4,600 (15' 1")			
Arm length	1,900 (6' 3")	2,100 (6' 11")	2,500 (8' 2")	3,000 (9' 10")
A Max. digging reach	7,730 (25' 4")	7,900 (25' 11")	8,310 (27' 3")	8,770 (28' 9")
A' Max. digging reach on ground	7,580 (24' 10")	7,750 (25' 0")	8,170 (26' 10")	8,630 (28' 4")
B Max. digging depth	4,890 (16' 1")	5,100 (16' 9")	5,500 (18' 1")	5,990 (19' 8")
B' Max. digging depth (8' level)	4,640 (15' 3")	4,870 (16' 0")	5,290 (17' 4")	5,810 (19' 1")
C Max. vertical wall digging depth	4,400 (14' 5")	4,600 (15' 1")	5,000 (16' 5")	5,400 (17' 9")
D Max. digging height	8,840 (29' 0")	8,970 (29' 5")	9,350 (30' 8")	9,730 (31' 11")
E Max. dumping height	6,350 (20' 10")	6,470 (21' 3")	6,850 (22' 6")	7,230 (23' 9")
F Min. front swing radius	1,860 (6' 1")	2,030 (6' 8")	1,980 (6' 6")	2,260 (7' 5")

Dimensions & Working Ranges

DIMENSIONS R145LCR-9 ADJUSTABLE BOOM

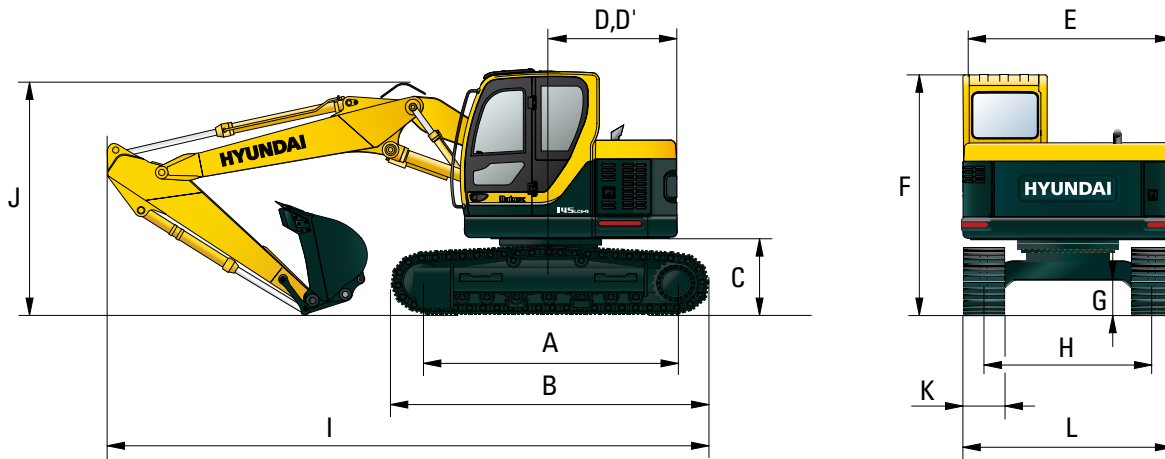

mm (ft · in)

mm (ft · in)

A Tumbler distance	3,090 (10' 2")	Boom length	4,900 (16' 1")		
B Overall length of crawler	3,820 (12' 6")	Arm length	2,100 (6' 11")	2,500 (8' 2")	
C Ground clearance of counterweight	930 (3' 1")	I Overall length	7,720 (25' 4")	7,690 (25' 3")	
D Tail swing radius	1,480 (4' 10")	J Overall height of boom	3,030 (9' 11")	3,060 (10' 1")	
D' Rear-end length	1,480 (4' 10")	K Track shoe width	500 (20")	600 (24")	700 (28")
E Overall width of upperstructure	2,500 (8' 2")	L Overall width	2,500 (8' 2")	2,600 (8' 6")	2,700 (8' 10")
F Overall height of cab	2,900 (9' 6")				
G Min. ground clearance	440 (1' 5")				
H Track gauge	2,000 (6' 7")				

WORKING RANGE R145LCR-9 ADJUSTABLE BOOM

mm (ft · in)

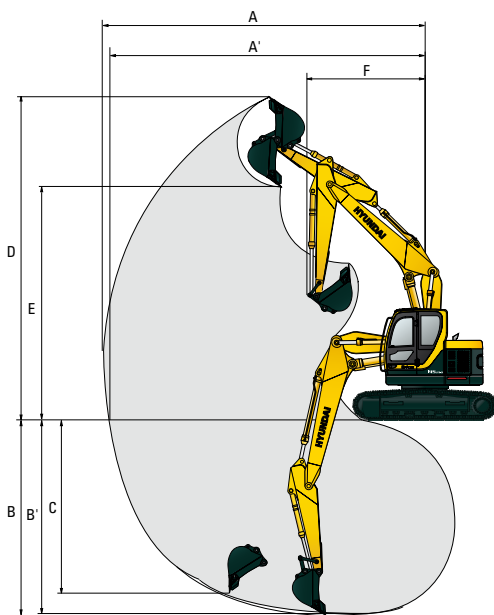

Boom length	4,900 (16' 1")		
Arm length	2,100 (6' 11")	2,500 (8' 2")	
A Max. digging reach	8,270 (27' 2")	8,675 (28' 6")	
A' Max. digging reach on ground	8,130 (26' 8")	8,540 (28' 6")	
B Max. digging depth	5,175 (17')	5,580 (18' 4")	
B' Max. digging depth (8' level)	5,080 (16' 8")	5,470 (17' 11")	
C Max. vertical wall digging depth	4,555 (14' 11")	5,015 (16' 5")	
D Max. digging height	9,340 (30' 8")	9,715 (31' 10")	
E Max. dumping height	6,850 (22' 6")	7,230 (23' 9")	
F Min. front swing radius	2,030 (6' 8")	1,980 (6' 6")	

Dimensions & Working Ranges

DIMENSIONS R145LCR-9 (DOZER TYPE)

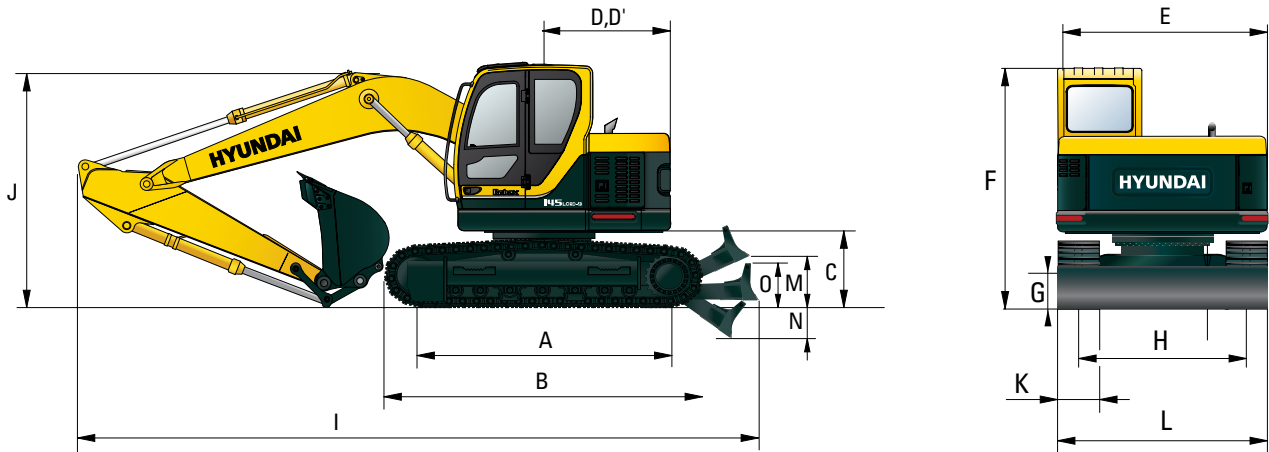

mm (ft · in)

mm (ft · in)

A Tumbler distance	3,090 (10' 2")	Boom length	4,600 (15' 1")			
B Overall length of crawler	3,820 (12' 6")	Arm length	1,900 (6' 3")	2,100 (6' 11")	2,500 (8' 2")	3,000 (9' 10")
C Ground clearance of counterweight	930 (3' 1")	I Overall length	7,840 (25' 9")	7,860 (25' 9")	7,820 (25' 8")	7,760 (25' 6")
D Tail swing radius	1,480 (4' 10")	J Overall height of boom	2,630 (8' 8")	2,710 (8' 11")	2,860 (9' 5")	3,210 (10' 6")
D' Rear-end length	1,480 (4' 10")	K Track shoe width	500 (20")	600 (24")	700 (28")	
E Overall width of upperstructure	2,500 (8' 2")	L Overall width	2,500 (8' 2")	2,600 (8' 6")	2,700 (8' 10")	
F Overall height of cab	2,900 (9' 6")					
G Min. ground clearance	440 (1' 5")					
H Track gauge	2,000 (6' 7")					
M Ground clearance of blade up	420 (1' 8")					
N Depth of blade down	430 (1' 6")					
O Height of blade	575 (1' 8")					

WORKING RANGE R145LCR-9 (DOZER TYPE)

mm (ft · in)

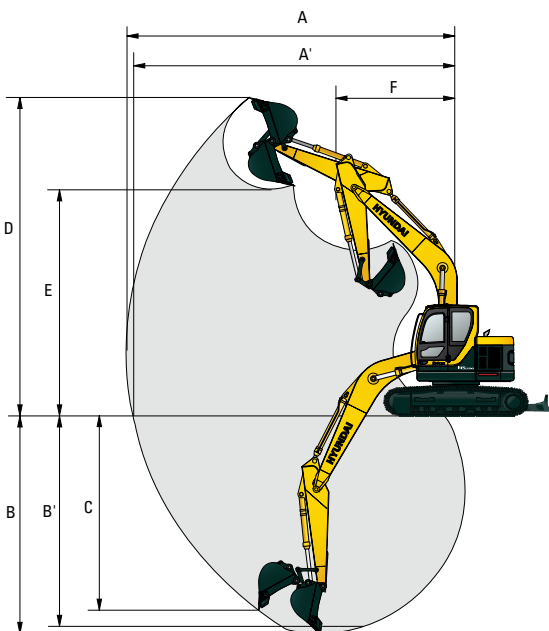

Boom length	4,600 (15' 1")			
Arm length	1,900 (6' 3")	2,100 (6' 11")	2,500 (8' 2")	3,000 (9' 10")
A Max. digging reach	7,730 (25' 4")	7,900 (25' 11")	8,310 (27' 3")	8,770 (28' 9")
A' Max. digging reach on ground	7,580 (24' 10")	7,750 (25' 0")	8,170 (26' 10")	8,630 (28' 4")
B Max. digging depth	4,890 (16' 1")	5,100 (16' 9")	5,500 (18' 1")	5,990 (19' 8")
B' Max. digging depth (8' level)	4,640 (15' 3")	4,870 (16' 0")	5,290 (17' 4")	5,810 (19' 1")
C Max. vertical wall digging depth	4,400 (14' 5")	4,600 (15' 1")	5,000 (16' 5")	5,400 (17' 9")
D Max. digging height	8,840 (29' 0")	8,970 (29' 5")	9,350 (30' 8")	9,730 (33' 11")
E Max. dumping height	6,350 (20' 10")	6,470 (21' 3")	6,850 (22' 6")	7,230 (23' 9")
F Min. front swing radius	1,860 (6' 1")	2,030 (6' 8")	1,980 (6' 6")	2,260 (7' 5")

Dimensions & Working Ranges

DIMENSIONS R145LCR-9 ADJUSTABLE BOOM (DOZER TYPE)

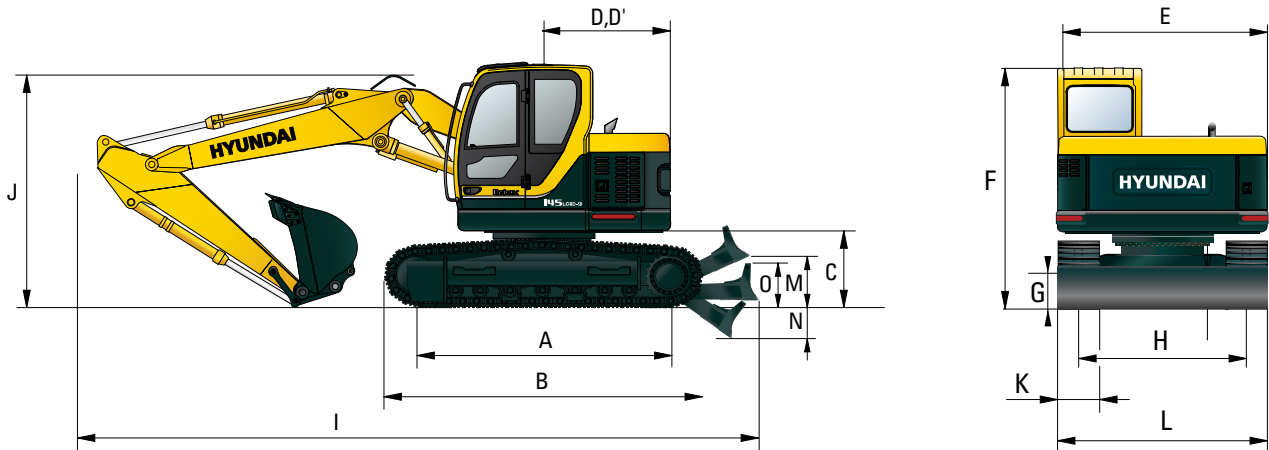

mm (ft · in)

mm (ft · in)

A Tumbler distance	3,090 (10' 2")	Boom length	4,900 (16' 1")		
B Overall length of crawler	3,820 (12' 6")	Arm length	2,100 (6' 11")	2,500 (8' 2")	
C Ground clearance of counterweight	930 (3' 1")	I Overall length	8,180 (26' 10")		
D Tail swing radius	1,480 (4' 10")	J Overall height of boom	3,030 (9' 11")		
D' Rear-end length	1,480 (4' 10")	K Track shoe width	500 (20")	600 (24")	700 (28")
E Overall width of upperstructure	2,500 (8' 2")	L Overall width	2,500 (8' 2")	2,600 (8' 6")	2,700 (8' 10")
F Overall height of cab	2,900 (9' 6")				
G Min. ground clearance	440 (1' 5")				
H Track gauge	2,000 (6' 7")				
M Ground clearance of blade up	420 (1' 8")				
N Depth of blade down	430 (1' 6")				
O Height of blade	575 (1' 8")				

WORKING RANGE R145LCR-9 ADJUSTABLE BOOM (DOZER TYPE)

mm (ft · in)

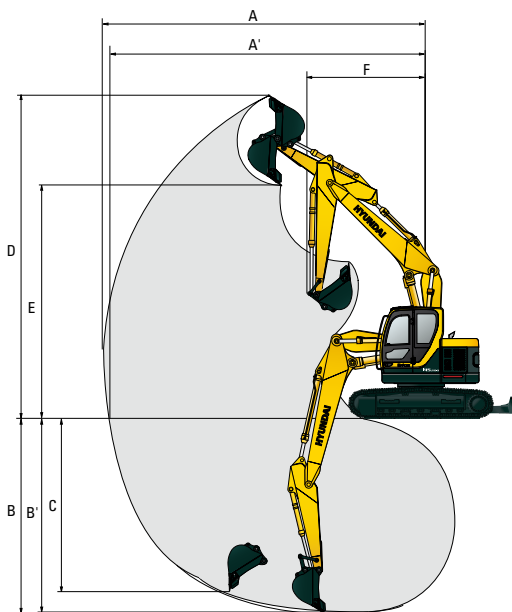

Boom length	4,900 (16' 1")		
Arm length	2,100 (6' 11")	2,500 (8' 2")	
A Max. digging reach	8,270 (27' 2")	8,675 (28' 6")	
A' Max. digging reach on ground	8,130 (26' 8")	8,540 (28' 6")	
B Max. digging depth	5,175 (17')	5,580 (18' 4")	
B' Max. digging depth (8' level)	5,080 (16' 8")	5,470 (17' 11")	
C Max. vertical wall digging depth	4,555 (14' 11")	5,015 (16' 5")	
D Max. digging height	9,340 (30' 8")	9,715 (31' 10")	
E Max. dumping height	6,850 (22' 6")	7,230 (23' 9")	
F Min. front swing radius	2,030 (6' 8")	1,980 (6' 6")	

Lifting Capacities

R145LCR-9



Rating over-front



Rating over-side or 360 degrees

Boom : 4.6 m (15' 1") / Arm : 1.9 m (6' 3") / Bucket : 0.52 m³ (0.68 yd³) SAE heaped / Shoe : 500 mm (20") triple grouser with 2,800 kg (6,170 lb) counterweight

Load point height m (ft)		Load radius								At max. reach				
		1.5 m (5.0 ft)		3.0 m (10.0 ft)		4.5 m (15.0 ft)		6.0 m (20.0 ft)		Capacity		Reach m (ft)		
6.0 m (20.0 ft)	kg					*3270	*3270					3710	2160	5.75
	lb					*7210	*7210					8180	4760	(18.9)
4.5 m (15.0 ft)	kg			*4960	*4960	*4310	3290					2770	1570	6.73
	lb			*10930	*10930	*9500	7250					6110	3460	(22.1)
3.0 m (10.0 ft)	kg			*7230	6040	*5000	3090	3310	1870			2410	1330	7.22
	lb			*15940	13320	*11020	6810	7300	4120			5310	2930	(23.7)
1.5 m (5.0 ft)	kg			*9120	5290	5160	2840	3200	1780			2310	1250	7.32
	lb			*20110	11660	11380	6260	7050	3920			5090	2760	(24.0)
Ground Line	kg			*8610	5040	4960	2670	3120	1700			2420	1310	7.06
	lb			*18980	11110	10930	5890	6880	3750			5340	2890	(23.2)
-1.5 m (-5.0 ft)	kg	*6830	*6830	*8140	5030	4900	2620					2850	1560	6.40
	lb	*15060	*15060	*17950	11090	10800	5780					6280	3440	(21.0)
-3.0 m (-10.0 ft)	kg			*6010	5170	*4100	2690					*2250	*2250	5.12
	lb			*13250	11400	*9040	5930					*4960	*4960	(16.8)

Boom : 4.6 m (15' 1") / Arm : 2.1 m (6' 11") / Bucket : 0.52 m³ (0.68 yd³) SAE heaped / Shoe : 500 mm (20") triple grouser with 2,800 kg (6,170 lb) counterweight

Load point height m (ft)		Load radius								At max. reach				
		1.5 m (5.0 ft)		3.0 m (10.0 ft)		4.5 m (15.0 ft)		6.0 m (20.0 ft)		Capacity		Reach m (ft)		
6.0 m (20.0 ft)	kg					*3440	3370					3490	2030	5.98
	lb					*7580	7430					7690	4480	(19.6)
4.5 m (15.0 ft)	kg			*4390	*4390	*4140	3310	*2560	1940			2650	1490	6.92
	lb			*9680	*9680	*9130	7300	*5640	4280			5840	3280	(22.7)
3.0 m (10.0 ft)	kg			*6870	6110	*4840	3100	3310	1880			2310	1260	7.39
	lb			*15150	13470	*10670	6830	7300	4140			5090	2780	(24.2)
1.5 m (5.0 ft)	kg			*9010	5330	5160	2840	3200	1770			2210	1190	7.49
	lb			*19860	11750	11380	6260	7050	3900			4870	2620	(24.6)
Ground Line	kg			*8870	5000	4940	2650	3100	1690			2310	1240	7.24
	lb			*19550	11020	10890	5840	6830	3730			5090	2730	(23.8)
-1.5 m (-5.0 ft)	kg	*6560	*6560	*8340	4970	4860	2580	3070	1660			2690	1460	6.60
	lb	*14460	*14460	*18390	10960	10710	5690	6770	3660			5930	3220	(21.7)
-3.0 m (-10.0 ft)	kg	*9060	*9060	*6360	5090	*4350	2630					*2390	2100	5.38
	lb	*19970	*19970	*14020	11220	*9590	5800					*5270	4630	(17.7)

Boom : 4.6 m (15' 1") / Arm : 2.5 m (8' 2") / Bucket : 0.52 m³ (0.68 yd³) SAE heaped / Shoe : 500 mm (20") triple grouser with 2,800 kg (6,170 lb) counterweight

Load point height m (ft)		Load radius								At max. reach				
		1.5 m (5.0 ft)		3.0 m (10.0 ft)		4.5 m (15.0 ft)		6.0 m (20.0 ft)		Capacity		Reach m (ft)		
6.0 m (20.0 ft)	kg					*2960	*2960					*2910	1720	6.50
	lb					*6530	*6530					*6420	3790	(21.3)
4.5 m (15.0 ft)	kg					*3460	3350	*2670	1960			2360	1300	7.37
	lb					*7630	7390	*5890	4320			5200	2870	(24.2)
3.0 m (10.0 ft)	kg			*6090	*6090	*4480	3130	3320	1880			2080	1110	7.81
	lb			*13430	*13430	*9880	6900	7320	4140			4590	2450	(25.6)
1.5 m (5.0 ft)	kg			*8480	5450	5180	2850	3190	1760			2000	1050	7.90
	lb			*18700	12020	11420	6280	7030	3880			4410	2310	(25.9)
Ground Line	kg			*9170	4990	4930	2630	3070	1650			2070	1080	7.67
	lb			*20220	11000	10870	5800	6770	3640			4560	2380	(25.2)
-1.5 m (-5.0 ft)	kg	*5850	*5850	*8700	4890	4810	2530	3020	1600			2370	1260	7.07
	lb	*12900	*12900	*19180	10780	10600	5580	6660	3530			5220	2780	(23.2)
-3.0 m (-10.0 ft)	kg	*8930	*8930	*7030	4970	*4770	2550					*2400	1730	5.97
	lb	*19690	*19690	*15500	10960	*10520	5620					*5290	3810	(19.6)
-4.5 m (-15.0 ft)	kg			*3750	*3750									
	lb			*8270	*8270									

Boom : 4.6 m (15' 1") / Arm : 3.0 m (9' 10") / Bucket : 0.52 m³ (0.68 yd³) SAE heaped / Shoe : 500 mm (20") triple grouser with 2,800 kg (6,170 lb) counterweight

Load point height m (ft)		Load radius								At max. reach				
		1.5 m (5.0 ft)		3.0 m (10.0 ft)		4.5 m (15.0 ft)		6.0 m (20.0 ft)		7.5 m (25.0 ft)		Capacity		Reach m (ft)
6.0 m (20.0 ft)	kg					*2560	*2560	*1730	*1730			*2600	1470	7.07
	lb					*5640	*5640	*3810	*3810			*5730	3240	(23.2)
4.5 m (15.0 ft)	kg					*2760	*2760	*2550	2000			2100	1140	7.86
	lb					*6080	*6080	*5620	4410			4630	2510	(25.8)
3.0 m (10.0 ft)	kg			*3690	*3690	*3690	3210	*3210	1910	*1430	1200	1880	980	8.27
	lb			*8140	*8140	*8140	7080	*7080	4210	*3150	2650	4140	2160	(27.1)
1.5 m (5.0 ft)	kg			*7740	5690	*5030	2920	3220	1780	*1990	1150	1800	920	8.36
	lb			*17060	12540	*11090	6440	7100	3920	*4390	2540	3970	2030	(27.4)
Ground Line	kg			*9190	5090	4970	2670	3080	1660	*1830	1100	1860	950	8.14
	lb			*20260	11220	10960	5890	6790	3660	*4030	2430	4100	2090	(26.7)
-1.5 m (-5.0 ft)	kg	*5380	*5380	*9060	4890	4810	2530	3000	1590			2090	1080	7.59
	lb	*11860	*11860	*19970	10780	10600	5580	6610	3510			4610	2380	(24.9)
-3.0 m (-10.0 ft)	kg	*7860	*7860	*7790	4900	4780	2500	3000	1590			*2460	1420	6.59
	lb	*17330	*17330	*17170	10800	10540	5510	6610	3510			*5420	3130	(21.6)
-4.5 m (-15.0 ft)	kg	*8050	*8050	*5160	5080	*3260	2620							
	lb	*17750	*17750	*11380	11200	*7190	5780							











- Lifting capacity is based on SAE J1097, ISO 10567.
- Lifting capacity of the Robex Series does not exceed 75% of the tipping load with the machine on firm, level ground or 87% of full hydraulic capacity.
- The load point is a hook located on the back of the bucket.
- (*) indicates the load limited by hydraulic capacity.

Lifting Capacities













R145LCR-9 ADJUSTABLE BOOM

 Rating over-front  Rating over-side or 360 degrees

Boom : 4.9 m (16' 1") / Arm : 2.1 m (6' 11") / Bucket : 0.52 m³ (0.68 yd³) SAE heaped / Shoe : 500 mm (20") triple grouser with 2,800 kg (6,170 lb) counterweight

Load point height m (ft)		Load radius								At max. reach		
		1.5 m (5.0 ft)		3.0 m (10.0 ft)		4.5 m (15.0 ft)		6.0 m (20.0 ft)		Capacity		Reach
												m (ft)
6.0 m (20.0 ft)	kg	*3440	*3440	*3680	*3680	*3490	3410			3050	1730	6.46
	lb	*7580	*7580	*8110	*8110	*7690	7520			6720	3810	(12.1)
4.5 m (15.0 ft)	kg	*3330	*3330	*4400	*4400	*3800	3300	*3400	1940	2380	1300	7.33
	lb	*7340	*7340	*9700	*9700	*8380	7280	*7500	4280	5250	2870	(24.0)
3.0 m (10.0 ft)	kg			*6780	5910	*4560	3030	3300	1840	2100	1110	7.77
	lb			*14950	13030	*10050	6680	7280	4060	4630	2450	(25.5)
1.5 m (5.0 ft)	kg					5080	2740	3170	1720	2010	1050	7.87
	lb					11200	6040	6990	3790	4430	2310	(25.8)
Ground Line	kg			*5890	4810	4860	2550	3060	1620	2100	1090	7.63
	lb			*12990	10600	10710	5620	6750	3570	4630	2400	(25.0)
-1.5 m (-5.0 ft)	kg			*8270	4820	4790	2490	3020	1590			
	lb			*18230	10630	10560	5490	6660	3510			

Boom : 4.9 m (16' 1") / Arm : 2.5 m (8' 2") / Bucket : 0.52 m³ (0.68 yd³) SAE heaped / Shoe : 500 mm (20") triple grouser with 2,800 kg (6,170 lb) counterweight

Load point height m (ft)		Load radius								At max. reach				
		1.5 m (5.0 ft)		3.0 m (10.0 ft)		4.5 m (15.0 ft)		6.0 m (20.0 ft)		7.5 m (25.0 ft)		Capacity		Reach
														m (ft)
6.0 m (20.0 ft)	kg	*2580	*2580	*2970	*2970	*3100	*3100	*2050	1970			2660	1480	6.96
	lb	*5690	*5690	*6550	*6550	*6830	*6830	*4520	4340			5860	3260	(22.8)
4.5 m (15.0 ft)	kg	*2210	*2210	*3110	*3110	*3430	3340	*3140	1960			2130	1140	7.77
	lb	*4870	*4870	*6860	*6860	*7560	7360	*6920	4320			4700	2510	(25.5)
3.0 m (10.0 ft)	kg			*6010	*6010	*4220	3070	3310	1850			1900	970	8.18
	lb			*13250	*13250	*9300	6770	7300	4080			4190	2140	(26.8)
1.5 m (5.0 ft)	kg			*7630	5190	5110	2760	3160	1710	2150	1110	1820	920	8.27
	lb			*16820	11440	11270	6080	6970	3770	4740	2450	4010	2030	(27.1)
Ground Line	kg			*6220	4780	4850	2530	3030	1590			1890	950	8.05
	lb			*13710	10540	10690	5580	6680	3510			4170	2090	(26.4)
-1.5 m (-5.0 ft)	kg			*8430	4720	4730	2430	2970	1540			2130	1090	7.49
	lb			*18580	10410	10430	5360	6550	3400			4700	2400	(24.6)
-3.0 m (-10.0 ft)	kg					4760	2450							
	lb					10490	5400							

1. Lifting capacity is based on SAE J1097, ISO 10567.
2. Lifting capacity of the Robex Series does not exceed 75% of the tipping load with the machine on firm, level ground or 87% of full hydraulic capacity.
3. The load point is a hook located on the back of the bucket.
4. (*) indicates the load limited by hydraulic capacity.

Lifting Capacities

R145LCR-9 (DOZER TYPE)



Rating over-front



Rating over-side or 360 degrees

Boom : 4.6 m (15' 1") / Arm : 1.9 m (6' 3") / Bucket : 0.52 m³ (0.68 yd³) SAE heaped / Shoe : 500 mm (20") triple grouser with 2,800 kg (6,170 lb) counterweight

Load point height m (ft)	Load radius								At max. reach			
	1.5 m (5.0 ft)		3.0 m (10.0 ft)		4.5 m (15.0 ft)		6.0 m (20.0 ft)		Capacity		Reach m (ft)	
6.0 m (20.0 ft)	kg					*3270	*3270			*3720	2300	5.75
	lb					*7210	*7210			*8200	5070	(18.9)
4.5 m (15.0 ft)	kg		*4960	*4960	*4310	3480				2960	1680	6.73
	lb		*10930	*10930	*9500	7670				6530	3700	(22.1)
3.0 m (10.0 ft)	kg		*7230	6370	*5000	3280	3530	2000		2580	1430	7.22
	lb		*15940	14040	*11020	7230	7780	4410		5690	3150	(23.7)
1.5 m (5.0 ft)	kg		*9120	5630	5490	3030	3430	1910		2480	1360	7.32
	lb		*20110	12410	12100	6680	7560	4210		5470	3000	(24.0)
Ground Line	kg		*8610	5370	5300	2860	3340	1840		2600	1420	7.06
	lb		*18980	11840	11680	6310	7360	4060		5730	3130	(23.2)
-1.5 m (-5.0 ft)	kg	*6830	*6830	*8140	5370	5240	2810			3050	1680	6.40
	lb	*15060	*15060	*17950	11840	11550	6190			6720	3700	(21.0)
-3.0 m (-10.0 ft)	kg			*6010	5510	*4100	2880			*2250	*2250	5.12
	lb			*13250	12150	*9040	6350			*4960	*4960	(16.8)

Boom : 4.6 m (15' 1") / Arm : 2.1 m (6' 11") / Bucket : 0.52 m³ (0.68 yd³) SAE heaped / Shoe : 500 mm (20") triple grouser with 2,800 kg (6,170 lb) counterweight

Load point height m (ft)	Load radius								At max. reach			
	1.5 m (5.0 ft)		3.0 m (10.0 ft)		4.5 m (15.0 ft)		6.0 m (20.0 ft)		Capacity		Reach m (ft)	
6.0 m (20.0 ft)	kg					*3440	*3440			*3550	2160	5.98
	lb					*7580	*7580			*7830	4760	(19.6)
4.5 m (15.0 ft)	kg		*4390	*4390	*4140	3500	*2560	2070		2830	1600	6.92
	lb		*9680	*9680	*9130	7720	*5640	4560		6240	3530	(22.7)
3.0 m (10.0 ft)	kg		*6870	6440	*4840	3290	3530	2010		2480	1370	7.39
	lb		*15150	14200	*10670	7250	7780	4430		5470	3020	(24.2)
1.5 m (5.0 ft)	kg		*9010	5670	5490	3030	3420	1900		2380	1290	7.49
	lb		*19860	12500	12100	6680	7540	4190		5250	2840	(24.6)
Ground Line	kg		*8870	5340	5280	2840	3320	1820		2480	1340	7.24
	lb		*19550	11770	11640	6260	7320	4010		5470	2950	(23.8)
-1.5 m (-5.0 ft)	kg	*6560	*6560	*8340	5310	5200	2770	3290	1790	2880	1580	6.60
	lb	*14460	*14460	*18390	11710	11460	6110	7250	3950	6350	3480	(21.7)
-3.0 m (-10.0 ft)	kg	*9060	*9060	*6360	5430	*4350	2820			*2390	2250	5.38
	lb	*19970	*19970	*14020	11970	*9590	6220			*5270	4960	(17.7)

Boom : 4.6 m (15' 1") / Arm : 2.5 m (8' 2") / Bucket : 0.52 m³ (0.68 yd³) SAE heaped / Shoe : 500 mm (20") triple grouser with 2,800 kg (6,170 lb) counterweight

Load point height m (ft)	Load radius								At max. reach			
	1.5 m (5.0 ft)		3.0 m (10.0 ft)		4.5 m (15.0 ft)		6.0 m (20.0 ft)		Capacity		Reach m (ft)	
6.0 m (20.0 ft)	kg					*2960	*2960			*2910	1840	6.50
	lb					*6530	*6530			*6420	4060	(21.3)
4.5 m (15.0 ft)	kg					*3460	*3460	*2670	2090	2530	1400	7.37
	lb					*7630	*7630	*5890	4610	5580	3090	(24.2)
3.0 m (10.0 ft)	kg		*6090	*6090	*4480	3320	3540	2010		2240	1210	7.81
	lb		*13430	*13430	*9880	7320	7800	4430		4940	2670	(25.6)
1.5 m (5.0 ft)	kg		*8480	5780	*5360	3040	3410	1890		2150	1140	7.90
	lb		*18700	12740	*11820	6700	7520	4170		4740	2510	(25.9)
Ground Line	kg		*9170	5330	5260	2820	3300	1790		2230	1180	7.67
	lb		*20220	11750	11600	6220	7280	3950		4920	2600	(25.2)
-1.5 m (-5.0 ft)	kg	*5850	*5850	*8700	5230	5150	2720	3240	1740	2550	1370	7.07
	lb	*12900	*12900	*19180	11530	11350	6000	7140	3840	5620	3020	(23.2)
-3.0 m (-10.0 ft)	kg	*8930	*8930	*7030	5300	*4770	2740			*2400	1860	5.97
	lb	*19690	*19690	*15500	11680	*10520	6040			*5290	4100	(19.6)
-4.5 m (-15.0 ft)	kg			*3750	*3750							
	lb			*8270	*8270							

Boom : 4.6 m (15' 1") / Arm : 3.0 m (9' 10") / Bucket : 0.52 m³ (0.68 yd³) SAE heaped / Shoe : 500 mm (20") triple grouser with 2,800 kg (6,170 lb) counterweight

Load point height m (ft)	Load radius										At max. reach			
	1.5 m (5.0 ft)		3.0 m (10.0 ft)		4.5 m (15.0 ft)		6.0 m (20.0 ft)		7.5 m (25.0 ft)		Capacity		Reach m (ft)	
6.0 m (20.0 ft)	kg					*2560	*2560	*1730	*1730			*2600	1580	7.07
	lb					*5640	*5640	*3810	*3810			*5730	3480	(23.2)
4.5 m (15.0 ft)	kg					*2760	*2760	*2550	2140			2260	1240	7.86
	lb					*6080	*6080	*5620	4720			4980	2730	(25.8)
3.0 m (10.0 ft)	kg		*3690	*3690	*3690	3400	*3210	2040	*1430	1300		2020	1070	8.27
	lb		*8140	*8140	*8140	7500	*7080	4500	*3150	2870		4450	2360	(27.1)
1.5 m (5.0 ft)	kg		*7740	6020	*5030	3110	3440	1910	*1990	1250		1950	1010	8.36
	lb		*17060	13270	*11090	6860	7580	4210	*4390	2760		4300	2230	(27.4)
Ground Line	kg		*9190	5430	5310	2860	3300	1790	*1830	1200		2010	1040	8.14
	lb		*20260	11970	11710	6310	7280	3950	*4030	2650		4430	2290	(26.7)
-1.5 m (-5.0 ft)	kg	*5380	*5380	*9060	5220	5140	2720	3220	1720			2250	1180	7.59
	lb	*11860	*11860	*19970	11510	11330	6000	7100	3790			4960	2600	(24.9)
-3.0 m (-10.0 ft)	kg	*7860	*7860	*7790	5240	5120	2690	3220	1720			*2460	1540	6.59
	lb	*17330	*17330	*17170	11550	11290	5930	7100	3790			*5420	3400	(21.6)
-4.5 m (-15.0 ft)	kg	*8050	*8050	*5160	*5160	*3260	2810							
	lb	*17750	*17750	*11380	*11380	*7190	6190							

- Lifting capacity is based on SAE J1097, ISO 10567.
- Lifting capacity of the Robex Series does not exceed 75% of the tipping load with the machine on firm, level ground or 87% of full hydraulic capacity.
- The load point is a hook located on the back of the bucket.
- (*) indicates the load limited by hydraulic capacity.

Lifting Capacities

R145LCR-9 ADJUSTABLE BOOM (DOZER TYPE)



Rating over-front



Rating over-side or 360 degrees

Boom : 4.9 m (16' 1") / Arm : 2.1 m (6' 11") / Bucket : 0.52 m³ (0.68 yd³) SAE heaped / Shoe : 500 mm (20") triple grouser with 2,800 kg (6,170 lb) counterweight

Load point height m (ft)		Load radius								At max. reach		
		1.5 m (5.0 ft)		3.0 m (10.0 ft)		4.5 m (15.0 ft)		6.0 m (20.0 ft)		Capacity		Reach
												m (ft)
6.0 m (20.0 ft)	kg	*3440	*3440	*3680	*3680	*3490	*3490			*3150	1860	6.46
	lb	*7580	*7580	*8110	*8110	*7690	*7690			*6940	4100	(21.2)
4.5 m (15.0 ft)	kg	*3330	*3330	*4400	*4400	*3800	3490	*3400	2070	2620	1410	7.33
	lb	*7340	*7340	*9700	*9700	*8380	7690	*7500	4560	5780	3110	(24.0)
3.0 m (10.0 ft)	kg			*6780	6240	*4560	3220	3610	1980	2320	1210	7.77
	lb			*14950	13760	*10050	7100	7960	4370	5110	2670	(25.5)
1.5 m (5.0 ft)	kg					*5380	2930	3470	1850	2230	1140	7.87
	lb					*11860	6460	7650	4080	4920	2510	(25.8)
Ground Line	kg			*5890	5150	5320	2740	3360	1760	2320	1190	7.63
	lb			*12990	11350	11730	6040	7410	3880	5110	2620	(25.0)
-1.5 m (-5.0 ft)	kg			*8270	5160	5250	2680	3320	1720			
	lb			*18230	11380	11570	5910	7320	3790			

Boom : 4.9 m (16' 1") / Arm : 2.5 m (8' 2") / Bucket : 0.52 m³ (0.68 yd³) SAE heaped / Shoe : 500 mm (20") triple grouser with 2,800 kg (6,170 lb) counterweight

Load point height m (ft)		Load radius								At max. reach				
		1.5 m (5.0 ft)		3.0 m (10.0 ft)		4.5 m (15.0 ft)		6.0 m (20.0 ft)		7.5 m (25.0 ft)		Capacity	Reach	
														m (ft)
6.0 m (20.0 ft)	kg	*2580	*2580	*2970	*2970	*3100	*3100	*2050	*2050			*2890	1590	6.96
	lb	*5690	*5690	*6550	*6550	*6830	*6830	*4520	*4520			*6370	3510	(22.8)
4.5 m (15.0 ft)	kg	*2210	*2210	*3110	*3110	*3430	*3430	*3140	2090			2350	1240	7.77
	lb	*4870	*4870	*6860	*6860	*7560	*7560	*6920	4610			5180	2730	(25.5)
3.0 m (10.0 ft)	kg			*6010	*6010	*4220	3260	*3450	1980			2100	1070	8.18
	lb			*13250	*13250	*9300	7190	*7610	4370			4630	2360	(26.8)
1.5 m (5.0 ft)	kg			*7630	5520	*5120	2950	3460	1840	*2330	1210	2020	1010	8.27
	lb			*16820	12170	*11290	6500	7630	4060	*5140	2670	4450	2230	(27.1)
Ground Line	kg			*6220	5120	5300	2720	3330	1730			2090	1040	8.05
	lb			*13170	11290	11680	6000	7340	3810			4610	2290	(26.4)
-1.5 m (-5.0 ft)	kg			*8430	5060	5190	2620	3270	1670			2360	1190	7.49
	lb			*18580	11160	11440	5780	7210	3680			5200	2620	(24.6)
-3.0 m (-10.0 ft)	kg					*5000	2640							
	lb					*11020	5820							

- Lifting capacity is based on SAE J1097, ISO 10567.
- Lifting capacity of the Robex Series does not exceed 75% of the tipping load with the machine on firm, level ground or 87% of full hydraulic capacity.
- The load point is a hook located on the back of the bucket.
- (*) indicates the load limited by hydraulic capacity.

STANDARD EQUIPMENT

ISO Standard cabin

All-weather steel cab with 360° visibility
Safety glass windows
Rise-up type windshield wiper
Sliding fold-in front window
Sliding side window
One key fits all lockable doors
Hot & cool box
Storage compartment & Ashtray
Transparent cabin roof-cover
Radio MP3 Player with AUX-input
Handsfree mobile phone system with USB-charging device
Sun visor

Computer aided power optimization (New CAPO) system

3-power modes, 3-work modes, User mode
Auto & one-touch deceleration system
Auto warm-up system
Overheat prevention system

Automatic temperature control

Air conditioner & heater
Defroster

Self-diagnostics system

Starting Aid (air grid heater) for cold weather

Centralized monitoring

LCD-display

Engine speed or Trip meter
Clock
Gauges
- Fuel level gauge
- Engine coolant temperature gauge
- Hyd. oil temperature gauge
Warning lamps
- Engine warning
- Communication error
- Low battery
- Air filter clogging
Indicators
- Max power
- Fuel warmer
- Auto deceleration

Door and cab locks, one key

Two outside rearview mirrors

Mechanical suspension seat with heater

Adjustable joysticks

Console box height adjust system

Four front working lights

Electric horn

Batteries (2 x 12 V x 80 AH)

Battery master switch

Removable clean-out screen for oil cooler

Automatic swing brake

Removable reservoir tank

Fuel pre-filter with fuel warmer

Boom holding system

Arm holding system

Counterweight (2,800 kg; 6,170 lb)

Track shoes (500 mm; 20")

Track rail guard

Accumulator for lowering work equipment

Electric transducer

Lower frame under cover

OPTIONAL EQUIPMENT

Fuel filler pump (35 ℓ/min)

Beacon lamp

Safety lock valve for boom cylinder with overload warning device

Safety lock valve for arm cylinder

Single-acting piping kit (breaker, etc.)

Double-acting piping kit (clamshell, etc.)

Quick coupler

Travel alarm

Arm

Extra Short arm (1.9 m; 6' 3")

Short arm (2.1 m; 6' 11")

Long arm (3.0 m; 9' 10")

Bucket

Various optional Buckets (SAE heaped)

Standard bucket (0.58 m³; 0.76 yd³)

Narrow bucket (0.23 m³; 0.30 yd³)

Narrow bucket (0.40 m³; 0.52 yd³)

Narrow bucket (0.46 m³; 0.60 yd³)

Narrow bucket (0.52 m³; 0.68 yd³)

Light duty bucket (0.65 m³; 0.85 yd³)

Slope finishing bucket (0.45 m³; 0.59 yd³)

Ditch cleaning bucket (0.55 m³; 0.72 yd³)

Cabin lights

Rain guard – Front window

Track shoes

Triple grouser shoes (500 mm; 20")

Triple grouser shoes (600 mm; 24")

Triple grouser shoes (700 mm; 28")

Additional cover under lower frame

Tool kit

Operator suit

Rearview camera

Pattern change valve (2 patterns)

Hi-mate (Remote Management System)

Standard and optional equipment may vary. Contact your Hyundai dealer for more information. The machine may vary according to International standards. All imperial measurements rounded off to the nearest pound or inch.

PLEASE CONTACT



Hyundai Heavy Industries Europe N.V.

VOSSENDAAL 11, 2440 GEEL, BELGIUM TEL: (32) 14-56-2200 FAX: (32) 14-59-3405