

UR-W546C

UR-W546C features maximum 4.05t lifting power to allow heavy load lifting operation.

It is capable of lifting maximum 4.05t at 2.5m with a size of only 1400mm wide. It offers a combination of fantastic accessibility and heavy lifting capacity. Standard Automatic stop for overloading device provides the benefit of overloading prevention for safety.

Max 16.0m
Hook height (Approx.)
(Above ground level)



Max 4.05t × 2.5m
Lifting capacity

Max 15.52m
Working radius

4920kg
Mass of crane



Radio remote control

SPECIFICATIONS

Crane model	UR-W546C2
Lifting capacity	Max. 4.05t at 2.5m
Working radius	Min. 0.66m, Max. 15.52m
Hook height (Approx.)	Above ground level Max. 16.0m
	Below ground level Max. 20.0m with 4-part line
Boom	Length Min. 3.93m to Max. 15.71m
	Extending speed [with electric power unit] 11.78m / 35.0 sec. [50Hz] 11.78m / 57.0 sec. [60Hz] 11.78m / 48.0 sec.
	Raising angle / speed [with electric power unit] 0° to 80° / 18.0 sec. [50Hz] 0° to 80° / 30.0 sec. [60Hz] 0° to 80° / 25.0 sec.
	Structure 6-section box beam type telescoping boom
Winch	Single line speed [with electric power unit] 44.0 m/min (at 4th layer) [50Hz] 34.0 m/min (at 4th layer) [60Hz] 40.0 m/min (at 4th layer)
	Hook speed [with electric power unit] 11.0 m/min (at 4th layer with 4-part line) [50Hz] 8.5 m/min (at 4th layer with 4-part line) [60Hz] 10.0 m/min (at 4th layer with 4-part line)
	Structure Hydraulic motor driven, spur gear reduction, with automatic mechanical brake and wire rope retaining roller
	Wire rope Construction : XP IWRC 6 x WS(26) / Diameter x Length : 8mm x 91.5m / Breaking strength : 47.1kN [4800 kgf]
Stewing	Hook block 4.00t capacity, 2 sheaves with safety latch
	Range 360° continuous rotation on a ball bearing race
	Speed [with electric power unit] 2.5 rpm [50Hz] 2.0 rpm [60Hz] 2.3 rpm
Outriggers	Horizontal, Vertical A double acting hydraulic cylinder, direct pushing type (Directly connected with hydraulic automatic lock device)
	Type Variable delivery piston pump
Hydraulic pump	Rated pressure 21.6 MPa [220 kgf/cm ²]
	Rated delivery 60 liters/min
	Rated revolution 2500 rpm
Hydraulic oil tank capacity	75 liters
Safety devices	Pressure relief valve for hydraulic circuit / Counterbalance valves for boom raising and boom telescoping cylinders / Pilot-operated check valves for outrigger cylinders (Horizontal) / Double pilot-operated check valves for outrigger cylinders (Vertical) / Boom angle indicator with load indicator / Hook safety latch / Automatic mechanical brake for winch / Automatic stop for overwinding / Overwinding alarm / Automatic stop for leaving minimum wire rope / Emergency stop button / Inter-lock device of crane and crawling levers / Inter-lock device of crane and outriggers / Level / Automatic stop for overloading (KM-100) / Digital load meter / Three colored lamp / Headlight / Boom outrigger monitor lamp

UNIC MINI-CRAWLER CRANE

WORKING RANGE & NET RATED LOADS (kg)

Outrigger ● Max-extended NOT max-extended

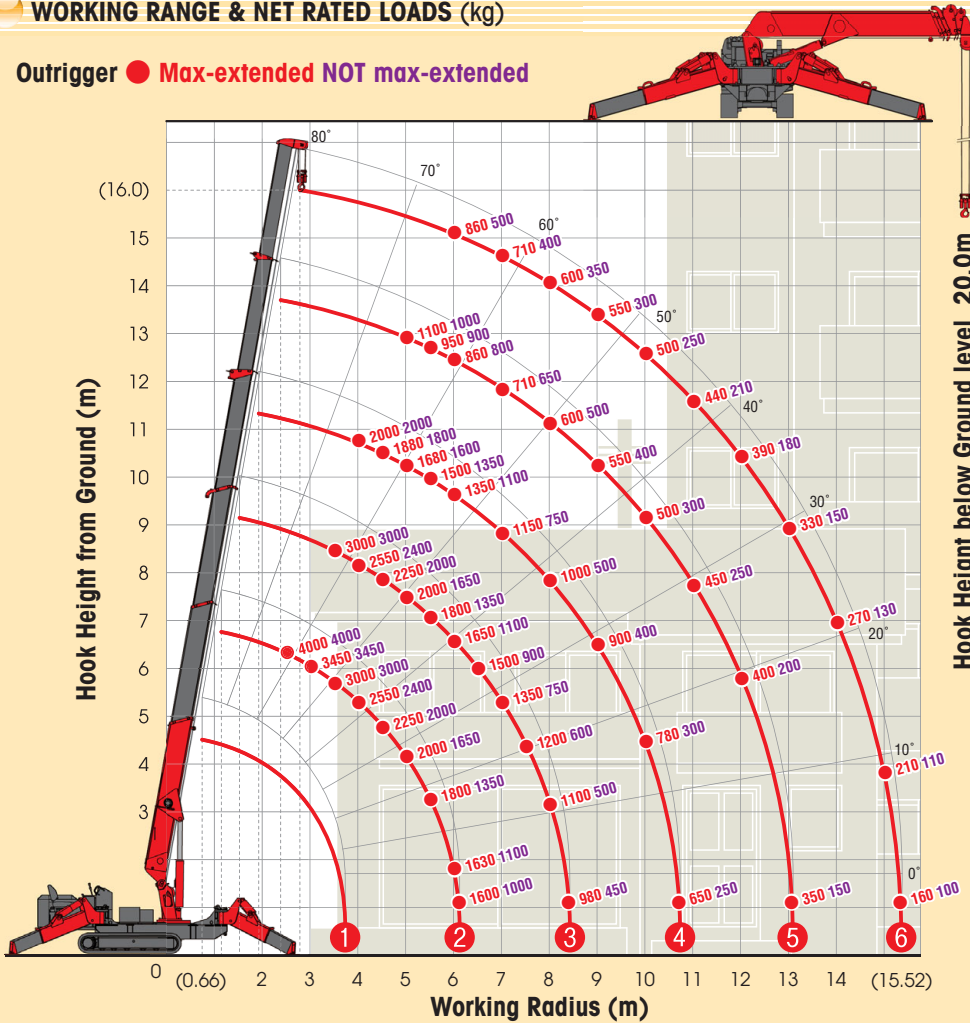

Hook Height below Ground level 20.0m

Automatic stop for overloading (KM-100)



Three colored lamp



Fly jib assembly (Options)

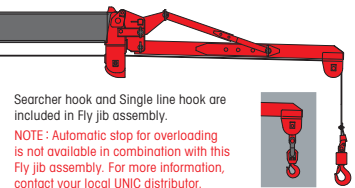

Searcher hook and Single line hook are included in Fly jib assembly.
NOTE: Automatic stop for overloading is not available in combination with this Fly jib assembly. For more information, contact your local UNIC distributor.

Length	2.0m
Lifting capacity	Max. 700kg
Tilt angles	0°, 20°, 40°, 60°

OUTRIGGER POSITIONS

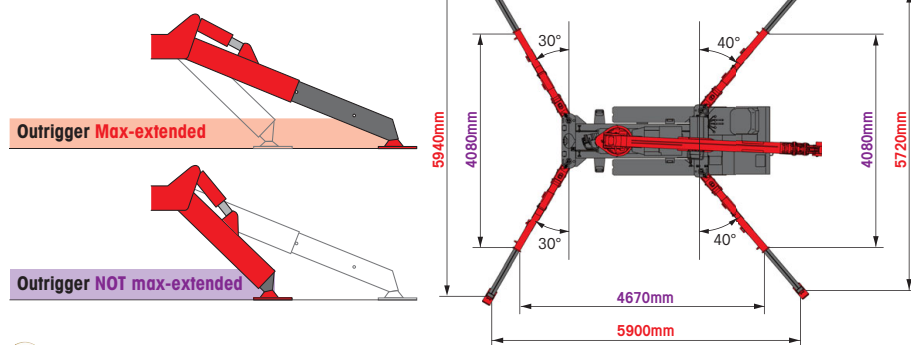

CRAWLING GEAR

Crane model	UR-W546C2
Crawling speed	0~3.0 km/h, forward / reverse
[with electric power unit]	[50Hz] 0~1.3 km/h [60Hz] 0~1.5 km/h
Hill climbing ability	23°
Tread length	1750mm
Ground contact pressure	46.1 kPa [0.47 kg/cm ²]
[with electric power unit]	47.1 kPa [0.48 kg/cm ²]
Engine manufacturer / model	Yanmar / 3TNV76
Displacement	1115cc
Maximum output	15.17kW(20.6PS) / 2500 rpm, Rated output
Fuel	Diesel
Fuel tank capacity	40 liters
Steering	Hydraulic drive independent of left / right
Starter	Starter motor

DIMENSIONS

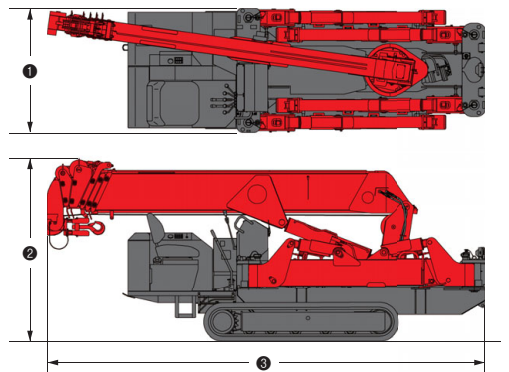

Crane model	UR-W546C2
① Total width	1380mm
② Total height	2035mm
③ Total length	4870mm
Mass of crane	4920kg [5070kg]

[with electric power unit]

Electric power unit specifications

Rated power	7.5kW (3-phase 4 poles)
Voltage	AC 200V or 400V (50Hz / 60Hz) 3 phase 4P

*Not included any cables.