

FUSO *CANTER*



**TURBO
INTERCOOLER**

All for you



FUSO CANTER

GENERAL SPECIFICATIONS		FE71, 4-Wheeler	FE83, 6-Wheeler	FE85Z, 6-Wheeler
DIMENSIONS				
Wheelbase	mm	2,500	3,350	4,170
Overall Length	mm	4,660	6,030	7,210
Overall Width	mm	1,695	1,995	2,135
Overall Height, approx. (H.)	mm	2,005	2,200	2,220
Tread	Front (mm)	1,390	1,655	1,665
	Rear (mm)	1,380	1,495	1,660
Ground Clearance, approx.	mm	200	200	210
	Cab to Rear Axle (C.A.)	mm	2,030	2,825
Cab to End Frame (C.E.)	mm	3,090	4,300	5,025
Frame Width	mm	700	750	753
Overhang	FOH - Front (mm)	1,000	1,145	1,145
	ROH - Rear (mm)	1,065	1,475	1,700
Crew	persons	3		
WEIGHT				
Curb Weight	kg	1,855	2,150	2,485
Payload	kg	2,545	3,850	5,715
Maximum G.V.W	kg	4,400	6,000	8,200
CALCULATED PERFORMANCE				
Max. Speed	Km/h	103	93	100
Max. Gradeability	(tan θ) %	50.5	38.5	37.0
Min. Turning Radius	m	5.1	6.0	7.3
ELECTRICAL SYSTEM				
Batteries	12V x 2, 65Ah @ 20 Hr. Rate			
Alternator Amp Rating	24V, AC, 50 Amp			
ENGINE				
Model	4D34-2AT5		4D34-2AT4	
Type	4-Stroke Cycle, Water-Cooled Turbocharged and Intercooled Direct Injection Diesel			
No. of Cylinders	4 In-Line			
Piston Displacement	cc 3,908			
Bore x Stroke	mm 104 x 115			
Maximum Output	PS / rpm	110 / 2,900		136 / 2,900
Maximum Torque	N-m / rpm	275 / 1,600		370 / 1,600
Air Cleaner	Dry Paper Element Type			
Fuel Tank Capacity	L	70	100	
DRIVELINE				
Clutch	Type	Single Dry Plate		
	Spring Type	Diaphragm Spring		
	Control	Hydraulic-Controlled		
Transmission	Type	5 forward, 1 reverse M/T		
		1st - 5th Synchronesh, Rev. Constantmesh	2nd - 5th Synchronesh, 1st and Rev. Constantmesh	
Gear Ratio	1st	5.181	5.380	
	2nd	2.865	3.028	
	3rd	1.593	1.700	
	4th	1.000	1.000	
	5th	0.739	0.722	
Reverse	5.181	5.380		
Final Reduction Gear	Single Reduction, Hypoid Gear			
Final Gear Ratio	5.714	6.166		
Transmission P.T.O.	Not Equipped			
CHASSIS				
Axle	Front	Reverse Elliot "I" Beam		
	Rear	Fully Floating		
Suspension	Front	Laminated Leaf Springs with Stabilizers	Laminated Leaf Springs	
	Rear	Laminated Leaf Springs		
Shock Absorbers	Type	Hydraulic Double Acting Telescopic		
	Front	Equipped		
Brake	Service	Hydraulic with Vacuum Servo Assistance, Dual Circuit		
	Parking	Internal Expanding Type on Propeller Shaft (Lever Type)		
Auxiliary	Exhaust Brake, Vacuum-Operated	Exhaust Brake, Vacuum-Operated, Butterfly Valve-Type		
WHEEL AND TIRE				
Tire	Front	Single, 7.50 R15LT-12PR 120 / 118M	Single, 7.00 R16LT-12PR 116 / 114L	Single, 7.50 R16LT 14PR
	Rear	Single, 7.50 R15LT-12PR 120 / 118M	Dual, 7.00 R16LT-12PR 116 / 114L	Dual, 7.50 R16LT 14PR
Wheel	15x6.00GS - 50mm - 8t, 6 studs, 2 pieces (Steel Rim)		16x5.50F - 115mm - 8t, 5 studs, 2 pieces (Steel Rim)	
Radial Tire with Tube (Including Spare Tire Carrier and Spare Tire)	Equipped			
Spare Tire	Steel Rim			
STEERING				
Gear Type	Recirculating Ball and Nut			
Power Steering	Equipped			
Steering Wheel	2-Spoke Urethane			
Tilt Adjust Function	Equipped			
Telescopic Adjust Function	Equipped			
Steering Lock	Equipped			
AUDIO SYSTEM				
Model and Type	1-DIN CD / MP3 / Tuner			
Speakers	2			
SAFETY				
Seatbelt	3P ELR x2 and 2P Lapbelt x1			
Collapsible Steering Wheel	Equipped			
Side Impact Beams	Equipped			



- Vinyl Seat Materials • 2-Spoke Urethane Steering Wheel
- 3P ELR x2 and 2P Lapbelt x1 Seatbelts



- Two-Tone Blue / Black Combination Center Instrument Panel
- Tachometer for FE85Z, 6-Wheeler

- 1-DIN CD / MP3 / AM-FM Tuner with 2 Speakers



Superior Cabin and Interior :

Aside from a visually exciting and aero-dynamically efficient cab, the Fuso Canter boasts of a very comfortable cabin with car-like features and more legroom.



Powerful yet Economical Diesel Engine
4-Stroke Cycle, Water-Cooled Turbocharged and Intercooled Direct Injection Diesel

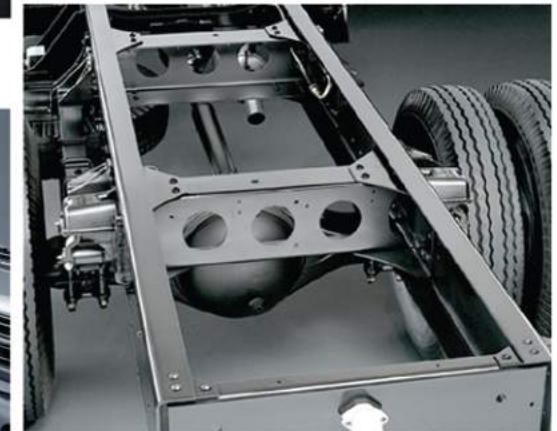

Strong, Reliable and Durable Chassis

Improvements on the chassis were made to ensure strength, durability and safety.



3 Years 100,000km WARRANTY

On Quality:
We seek excellence in our products and services and recognize that customer satisfaction is the essence of our mission.

www.mitsubishi-motors.com.ph



1. Note: MMPC reserves the right to alter any specification and pricing details without prior notice. (Issuance date: April 28, 2015)
2. Photos and specs shown in this flyer may vary from actual unit.

BF03002007

FUSO authorized distributor
Mitsubishi Motors Philippines Corporation