



[www.mitforklift.com.sg](http://www.mitforklift.com.sg)



*Ready to Perform  
to Your Applications*



**RBS-CA**  
S E R I E S

Reach Trucks  
0.9-3.0 ton



[enquiry@mitforklift.com.sg](mailto:enquiry@mitforklift.com.sg)  
[www.mitforklift.com.sg](http://www.mitforklift.com.sg)

Copyright © 2008 by MCFS, All Rights Reserved. All registered trademarks are the property of their respective owners. Printed in Singapore.

FMIT0081

(03/08)

PRESENTED BY:

Note: Performance specifications may vary depending on standard manufacturing tolerances, vehicle condition, types of tyres, floor or surface conditions, applications or operating environment. Trucks may be shown with non-standard options. Specific performance requirements and locally available configurations should be discussed with your Mitsubishi forklift truck dealers. Mitsubishi Forklift Trucks follows a policy of continual product improvement. For this reason, some materials, options and specifications could change without notice.

**Mitsubishi**  
*Reach Trucks*  
**RBS-CA Series**



**Reach New Heights  
with the RBS-CA Series**

Today's demanding warehouse applications call for a new generation of reach trucks. Introducing the new Mitsubishi RBS-CA Series Electric Reach Truck. This innovative truck is designed to deliver what you need, every day, every shift. Outstanding features such as energy-efficient AC drive and hydraulic motors, regenerative braking system, performance mode setting and on-board diagnostics, are built and configured to your performance needs.

Mitsubishi forklift trucks are built to deliver Performance with Efficiency, and Safety with Comfort, to enable you to reach new heights in productivity. Indeed, delivering what you need is our obsession.

# ADVANCED TECHNOLOGY

## AC POWER

AC Power is Mitsubishi Forklift Truck's multi-functional centralised control system for AC control. This system, which features advanced intelligence to optimise the reciprocal relationship between the operator and forklift, exhibits higher level and more powerful capabilities while integrating travel operation, hydraulic operation and electric power steering.

## SELF-DIAGNOSIS CAPABILITY

The RBS-CA series is equipped with computers to perform diagnosis of faults automatically. In case of a malfunction, a message on the monitor alerts the operator. This speeds up maintenance and repair as problems are quickly located and isolated.

## EASY-TO-READ DISPLAY

A vacuum fluorescent display (VFD) is strategically positioned at the front of the operator's compartment. Operators are given quick access to important information as data such as travelling speed, battery discharge status, current time and key-on hours are displayed in real time. The display is easy to read and understand, so monitoring can be done effortlessly.



## MULTIPLE DRIVE MODES

To accommodate changes in working conditions and differences in operators' level of experience, there are eight drive modes and three acceleration settings to choose from. These range from the "ECONOMY" mode for energy saving to "POWER" for heavy duty.

## INCHING CAPABILITY

Adopting AC Power and electronic control makes it possible for the reach truck to make very fine adjustments during movement, a function that will prove useful during loading operations.

## REGENERATIVE BRAKING

When the brakes are depressed, electrical power is transmitted back to the battery. Less power is also required for braking so wearing of the brake lining is reduced, thus extending the lifespan of the lining.

## REGENERATIVE PLUGGING

If the reach truck's direction of travel is reversed when cruising, the motor transfers electrical energy back to the battery.

## REGENERATIVE DECELERATION

When the accelerator lever is released while travelling, the motor slows down to create a sensation of gradual deceleration and at the same time transfers energy back to the battery.

# ECONOMICAL

## SIDE BATTERY LOADING

The RBS-CA series reach trucks are designed with side battery loading to suit most of the reach truck users who do frequent battery changes.

## REDUCED MAINTENANCE

The usage of AC motors has eliminated the need for brushes and contactors. With fewer electrical components to maintain, maintenance costs correspondingly become lower.



# PERFORMANCE

## POWERFUL AC MOTORS

The RBS-CA series employs high capacity AC motors on its drive and hydraulic systems. This enables greater acceleration and faster lifting speeds and ultimately brings about higher efficiency.

## LESS RE-CHARGE

Besides enabling the regenerative capabilities on the RBS-CA reach truck, the on-board computer also manages the power consumption intelligently. Hence, frequent re-charge is not necessary as the battery provides ample power to last longer periods of operation.

## SMALL TURNING RADIUS

With a turning radius among the best in the industry, the RBS-CA series reach truck is capable of handling extremely tight turns, and can be used easily in narrow aisles. The electric power steering (EPS) feature also allows steering to be done with ease at low speeds.

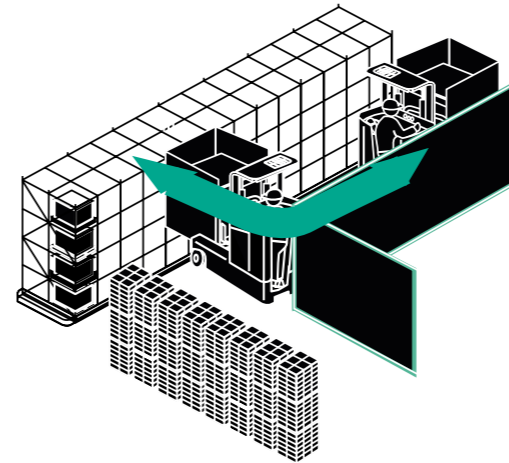

## STABILITY FOR HIGH-LIFTING

The low centre of gravity increases the stability of the RBS-CA series reach truck, minimising capacity degradation when lifting to higher racks. The standard 1.5 ton model is capable of lifting maximum rated loads (1,500 kg) up to 4 metres, while the long wheelbase model can do the same up to 5 metres.

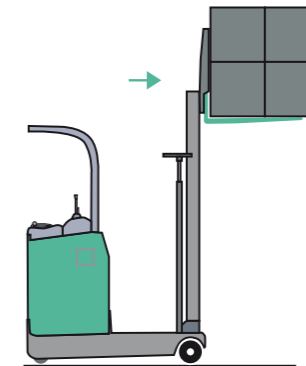

## STABILITY DURING MOVEMENT

The tendency to roll-over during turning is countered by an intelligent suspension system. Together with the low centre of gravity, stability during movement is enhanced.

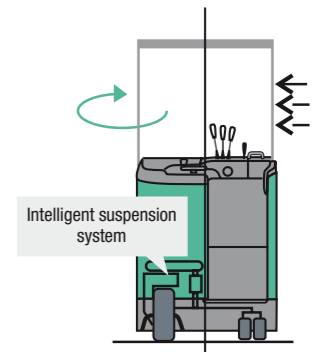

# SAFETY AND COMFORT

## DYNAMIC SUSPENSION SYSTEM

To counter the possibility of reach trucks rolling over when making turns, the RBS-CA series has a suspension system that reacts to balance the vehicles. Swaying of the body and lifting of the wheels during sharp turns are minimised. The risk of toppling over during lifting operations is also reduced.

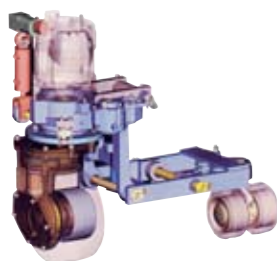

## ANTI-SLIP FUNCTION (ON OPTIONAL H-TYPE TRUCKS ONLY)

On the RBS-CA high performance reach trucks, features are added to prevent skidding problems which frequently occur during turning and when operating in refrigerated and freezer warehouses. An electric load wheel brake is installed on the H-type RBS-CA series to increase overall traction on slippery floors during braking. Electric load wheel brakes are more reliable than hydraulic brakes as there is no possibility of brake failure due to oil evaporation or freezing.

### When starting/stopping

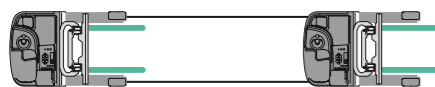

RBS-CA (High Performance model) with Anti-Slip Function

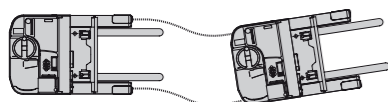

Reach truck without Anti-Slip Function

## REINFORCED REAR FRAME

The structure of the rear frame is strengthened to enhance the safety of the operator.



## REINFORCED OVERHEAD GUARD

The overhead guard is designed for enhanced rigidity, and at the same time maintaining its superior overall visibility.



## LOAD WHEEL GUARD

Additional protection is provided for the front load wheel.



## AUTOMATIC POWER OFF

Power is automatically off when the reach truck is left to idle for more than 15 minutes. This reduces energy wastage as well as the possibility of accidents.

## NEUTRAL SAFETY FEATURE

When the hydraulic lever or the accelerator lever is in use, turning on the key switch will cause an error message to appear on the display while all truck functions are disabled. Resetting is done by releasing all levers and turning on the switch again.

## WIDER ANGLE OF VIEW

The overhead guard and mast structures are designed to provide greater visibility for the operator.

## SMALL-DIAMETER STEERING WHEEL

As the need for large arm movements is eliminated through a smaller wheel, operator fatigue is reduced, and working stamina increased.

## SPACIOUS OPERATOR COMPARTMENT

The safe and spacious operator compartment offers greater room for the operator, thus raising his level of comfort.

## LOW NOISE LEVEL

AC Power of the RBS-CA series reach truck ensures its noise level is one of the lowest in its class. By cutting down chopping hum and contactor noise, hearing discomfort is minimised.

## MAST WITH SHOCK-REDUCTION FEATURE

The improved mast provides shock reduction during both lifting and lowering, slowing the forks automatically when it approaches the ground (soft landing). For duplex and triplex masts, shock absorption function during lifting is a standard feature. This not only reduces the operator's stress, but also prevents possible load damages.

## COMPUTER-CONTROLLED BATTERY CHARGER

After the operator activates the start button, the computer analyses the power remaining in the battery and optimises the charging process. It automatically extends the charging time in cold weather.

## WAIST AND KNEE PADS

The RBS-CA series provides a large waist pad adjustable according to the height of the operator. Large knee pads are also installed as standard items. The pads provide cushioning, increase comfort level and reduce possible impact-stress injury.



## LARGE BRAKE PEDAL

The large brake pedal facilitates usage and enhances comfort and safety.



## LASER POINTER (OPTIONAL)

In a poorly-lit environment, the RBS-CA reach truck can be equipped with a laser pointer that projects a red line on the pallet, showing the position where the forks will reach. The levelling lamps help operators level the forks when gauging using the naked eyes become difficult. This optional feature enhances work efficiency and improves safety.

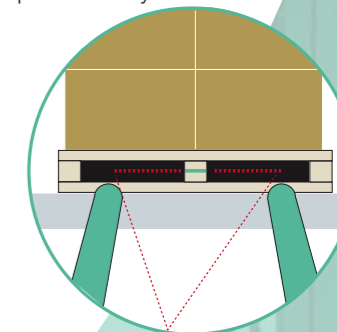

# SERVICEABILITY

## EASY ACCESS TO COMPONENTS:



### CONTROLLER

The controller cover can be removed completely for quick access and maintenance.

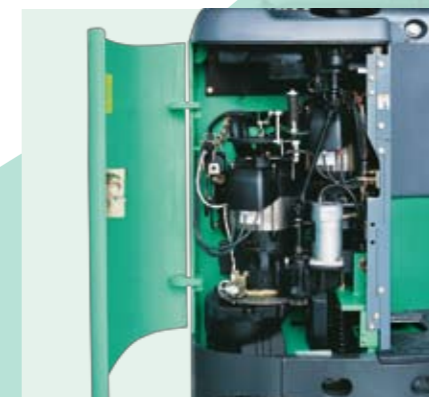

### MOTORS

The side-swing door of motors can be opened to a wide angle, making maintenance an easy task.



### BATTERY

Battery maintenance and replacement can be performed with minimal effort with the use of battery rollers and the battery stand provided as standard equipment.

# RBS-CA Series

## Reach Truck • AC Power

### 0.9 - 3.0ton

ITEM	SUMMARY	UNIT	STANDARD SERIES																							
			RBS9CA	RBSA9LCA	RBS10CA	RBS13CA	RBS13LCA	RBS10WCA	RBS13WCA	RBS13WLCA	RBS14CA	RBS14LCA	RBS15CA	RBS15LCA	RBS18CA	RBS18LCA	RBS20CA	RBS20LCA	RBS25CA	RBS25LCA	RBS30CA	RBS30LCA				
1	Model		RBS9CA	RBSA9LCA	RBS10CA	RBS13CA	RBS13LCA	RBS10WCA	RBS13WCA	RBS13WLCA	RBS14CA	RBS14LCA	RBS15CA	RBS15LCA	RBS18CA	RBS18LCA	RBS20CA	RBS20LCA	RBS25CA	RBS25LCA	RBS30CA	RBS30LCA				
2	Rated capacity	kg	900	900	1000	1250	1250	1000	1250	1250	1350	1350	1500	1500	1800	1800	2000	2000	2500	2500	3000	3000				
3	Load center	mm	400	500	500	500	500	500	500	500	500	500	500	500	500	500	500	500	500	500	500	500				
4	Motor Type		AC	AC	AC	AC	AC	AC	AC	AC	AC	AC	AC	AC	AC	AC	AC	AC	AC	AC	AC	AC				
5	Operator type		Stand-on	Stand-on	Stand-on	Stand-on	Stand-on	Stand-on	Stand-on	Stand-on	Stand-on	Stand-on	Stand-on	Stand-on	Stand-on	Stand-on	Stand-on	Stand-on	Stand-on	Stand-on	Stand-on	Stand-on				
6	Lift height	H3+s mm	3000	4000	3000	3000	4000	3000	3000	4000	3000	4000	3000	4000	3000	4000	3000	4000	3000	4000	3000	4000				
7	Free lift	H2+s mm	405	405	405	405	405	405	405	405	405	405	405	405	405	405	400	400	400	400	400	400				
8	Tilt angle	Upward / Downward a/b deg.	5 / 3	5 / 3	5 / 3	5 / 3	5 / 3	5 / 3	5 / 3	5 / 3	5 / 3	5 / 3	5 / 3	5 / 3	5 / 3	5 / 3	5 / 3	5 / 3	5 / 3	5 / 3	5 / 3	5 / 3				
9	Fork Size	Length x Width x Thickness l/b/s mm	1070 / 100 / 35	1070 / 100 / 35	1070 / 100 / 35	1070 / 100 / 35	1070 / 100 / 35	1070 / 100 / 35	1070 / 100 / 35	1070 / 100 / 35	1070 / 100 / 35	1070 / 100 / 35	1070 / 100 / 35	1070 / 100 / 35	1070 / 100 / 38	1070 / 100 / 38	1070 / 122 / 40	1070 / 122 / 40	1070 / 122 / 40	1070 / 122 / 40	1070 / 122 / 44	1070 / 122 / 44				
10	Overall length	L1 mm	2075	2075	2075	2075	2155	2130	2130	2170	2200	2200	2200	2200	2205	2255	2320	2320	2320	2370	2430	2530				
11	Length	Frame mm	1392	1472	1472	1612	1692	1447	1597	1647	1597	1697	1697	1877	1877	1927	1901	2071	2071	2141	2176	2371				
12	To fork face	L2 mm	1005	1005	1005	1005	1085	1060	1060	1100	1130	1130	1130	1130	1135	1185	1250	1250	1250	1300	1360	1460				
13	Reach Stroke	E mm	420	500	500	640	640	420	570	570	500	600	600	780	780	780	680	850	850	870	840	940				
14	Width	Overall width B mm	990	990	990	990	990	1090	1090	1090	1090	1090	1090	1090	1090	1090	1165	1165	1215	1215	1230	1230				
15	Between Legs	mm	655	655	655	655	655	750	750	750	750	750	750	750	750	750	795	795	795	795	795	795				
16	Frame	mm	990	990	990	990	990	1090	1090	1090	1090	1090	1090	1090	1090	1090	1165	1165	1165	1165	1165	1165				
17	Mast Lowered Height	H1 mm	1995	2495	1995	1995	2495	1995	1995	2495	1995	2495	1995	2495	1995	2495	2050	2550	2050	2550	2050	2550				
18	Mast Extended Height	H4 mm	3900	4900	3900	3900	4900	3900	3900	4900	3900	4900	3900	4900	3900	4900	3950	4950	3950	4950	4050	5050				
19	Overhead Guard Height	H6 mm	2220	2220	2220	2220	2220	2220	2220	2220	2220	2220	2220	2220	2220	2220	2330	2330	2330	2330	2330	2330				
20	Front Overhang	x mm	175	175	175	175	175	175	175	175	175	175	175	175	180	180	180	180	180	180	180	180				
21	Min. Turning Radius	Wa mm	1260	1330	1330	1470	1560	1315	1460	1510	1460	1555	1555	1735	1735	1785	1750	1940	1940	2000	2040	2240				
22	90° Turning Aisle*	1100 x 1100 Pallet mm	1705	1730	1730	1790	1840	1750	1810	1840	1820	1860	1860	1940	1940	1970	2000	2090	2120	2155	2175	2280				
23	90° Stacking Aisle*	1100 x 1100 Pallet Ast mm	2475	2480	2480	2510	2600	2530	2555	2605	2610	2625	2625	2680	2680	2730	2765	2840	2840	2885	2945	3085				
24	Travel speed	Laden / Unladen km/h	9.5 / 10.5	9.5 / 10.5	9.5 / 10.5	9.5 / 10.5	9.5 / 10.5	9.5 / 10.5	9.5 / 10.5	9.5 / 10.5	9.5 / 10.5	9.5 / 10.5	9.5 / 10.5	9.5 / 10.5	9.5 / 10.5	9.5 / 10.5	10 / 11.5	10 / 11.5	9.5 / 11.5	9.5 / 11.5	9.0 / 11.0	9.0 / 11.0				
25	Lifting speed	Laden / Unladen mm/s	275 / 450	275 / 450	265 / 450	240 / 450	240 / 450	340 / 540	320 / 540	320 / 540	310 / 540	310 / 540	310 / 540	310 / 540	300 / 540	300 / 540	290 / 490	290 / 490	270 / 490	270 / 490	220 / 400	220 / 400				
26	Max. Gradeability	3min. rating, 1.5km/h and over %	10 / 14.3	10 / 14.3	10 / 14.3	10 / 14.3	10 / 14.3	10 / 14.3	10 / 14.3	10 / 14.3	10 / 14.3	10 / 14.3	10 / 14.3	10 / 14.3	10 / 14.3	10 / 14.3	10 / 14.3	10 / 14.3	10 / 14.3	10 / 14.3	10 / 14.3	10 / 14.3				
27	Service weight	without battery kg	1450	1540	1480	1640	1800	1620	1740	1890	1730	1780	1720	1820	1780	1920	2310	2440	2400	2530	2640	2780				
28	Front, Load (Rubber)		ø255x 114	ø255x 114	ø255x 114	ø255x 114	ø255x 114	ø255x 114	ø255x 114	ø255x 114	ø254x 114/ Urethane	ø254x 114/ Urethane	ø254x 114/ Urethane	ø254x 114/ Urethane	ø254x 114/ Urethane	ø254x 114/ Urethane	ø267x 114/ Urethane	ø267x 114/ Urethane	ø267x 135/ Urethane	ø267x 135/ Urethane	ø267x 135/ Urethane	ø267x 135/ Urethane				
29	Tyres	Rear, Drive (Rubber)	ø280x 135	ø280x 135	ø280x 135	ø280x 135	ø280x 135	ø330x 145	ø330x 145	ø330x 145	ø330x 145	ø330x 145	ø330x 145	ø330x 145	ø330x 145	ø330x 145	ø330x 145	ø380x 165	ø380x 165	ø380x 165	ø380x 165	ø380x 165	ø380x 165			
30		Rear, Caster (Rubber)	ø178x 73	ø178x 73	ø178x 73	ø178x 73	ø178x 73	ø178x 73	ø178x 73	ø178x 73	ø178x 73	ø178x 73	ø178x 73	ø178x 73	ø178x 73	ø178x 73	ø204x 76	ø204x 76	ø204x 76	ø204x 76	ø204x 76/ Urethane	ø204x 76/ Urethane				
31	Wheelbase	y mm	1040	1120	1120	1260	1260	1095	1245	1245	1245	1345	1345	1525	1525	1525	1530	1700	1700	1770	1800	2000				
32	Tread	Front mm	876	876	876	876	876	976	976	976	976	976	976	976	976	976	1051	1051	1080	1080	1095	1095				
33		Rear mm	580	580	580	580	580	680	680	680	680	680	680	680	680	680	726	726	726	726	726	726				
34	Service brake	Mech. / Hydr. / Electr. / Pneum.	Mech.	Mech.	Mech.	Mech.	Mech.	Mech.	Mech.	Mech.	Mech.	Mech.	Mech.	Mech.	Mech.	Mech.	Mech.	Mech.	Mech.	Mech.	Mech.	Mech.				
35	Parking brake	Foot / Hand / Deadman	Deadman	Deadman	Deadman	Deadman	Deadman	Deadman	Deadman	Deadman	Deadman	Deadman	Deadman	Deadman	Deadman	Deadman	Deadman	Deadman	Deadman	Deadman	Deadman	Deadman				
36	Battery	Type	11D-F4N-E	11D-F4N-E	11D-F6A-E	11D-F6A-E	11D-F6A-E	11E-F3A-E	11E-F3A-E	11E-F3A-E	11D-F3C-E	11D-F3C-E	11F-F4N-E	11F-F4N-E	11F-F4N-E	11F-F4N-E	35T-F5A-E	35T-F5A-E	35T-F5A-E	35T-F5A-E	35T-GF370-E	35T-GF370-E				
37		Voltage / Capacity hrs (5hr. Rating)	24 / 280	24 / 280	24 / 390	24 / 390	24 / 390	48 / 201	48 / 201	48 / 201	48 / 210	48 / 210	48 / 280	48 / 280	48 / 280	48 / 280	48 / 320	48 / 320	48 / 320	48 / 320	48 / 370	48 / 370				
38		Weight kg	230	230	290	290	290	340	340	340	400	400	450	450	450	450	520	520	520	520	560	560				
39	Drive motor	60min. Rating kw	2.6	2.6	2.6	2.6	2.6	4.3	4.3	4.3	4.3	4.3	4.3	4.3	4.3	4.3	5.0	5.0	5.0	5.0	5.0	5.0				
40		control	FET	FET	FET	FET	FET	FET	FET	FET	FET	FET	FET	FET	FET	FET	FET	FET	FET	FET	FET	FET				
41	Hydraulic motor	5min. Rating kw	6.0	6.0	6.0	6.0	6.0	8.8	8.8	8.8	8.8	8.8	8.8	8.8	8.8	8.8	11.0	11.0	11.0	11.0	11.0	11.0				
42		control	FET	FET	FET	FET	FET	FET	FET	FET	FET	FET	FET	FET	FET	FET	FET	FET	FET	FET	FET	FET				
43	Power steering motor	60min. Rating kw	0.15	0.15	0.15	0.15	0.15	0.3	0.3	0.3	0.3	0.3	0.3	0.3	0.3	0.3	0.3	0.3	0.3	0.3	0.3	0.3				
44		control	FET	FET	FET	FET	FET	FET	FET	FET	FET	FET	FET	FET	FET	FET	FET	FET	FET	FET	FET	FET				
45	Charger (Option)	Type (Built-in / Stationary)	Stationary	Stationary	Stationary	Stationary	Stationary	Stationary	Stationary	Stationary	Stationary	Stationary	Stationary	Stationary	Stationary	Stationary	Stationary	Stationary	Stationary	Stationary	Stationary	Stationary				
46		Charging Method	Automatic	Automatic	Automatic	Automatic	Automatic	Automatic	Automatic	Automatic	Automatic	Automatic	Automatic	Automatic	Automatic	Automatic	Automatic	Automatic	Automatic	Automatic	Automatic	Automatic	Automatic			
47		Input φ/V	3 / 200	3 / 200	3 / 200	3 / 200	3 / 200	3 / 200	3 / 200	3 / 200	3 / 200	3 / 200	3 / 200	3 / 200	3 / 200	3 / 200	3 / 200	3 / 200	3 / 200	3 / 200	3 / 200	3 / 200				
48		Capacity kVA	2.4	2.4	3.4	3.4	3.4	3.8	3.8	3.8	3.8	3.8	4.7	4.7	4.7	4.7	4.7	4.7	4.7	4.7	6.5	6.5				

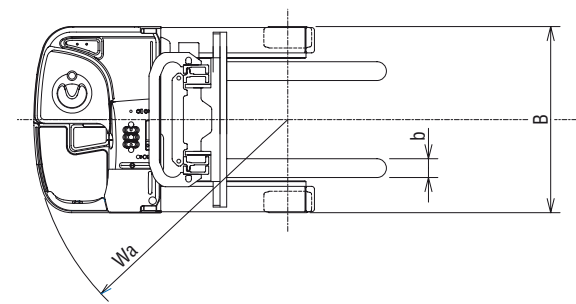
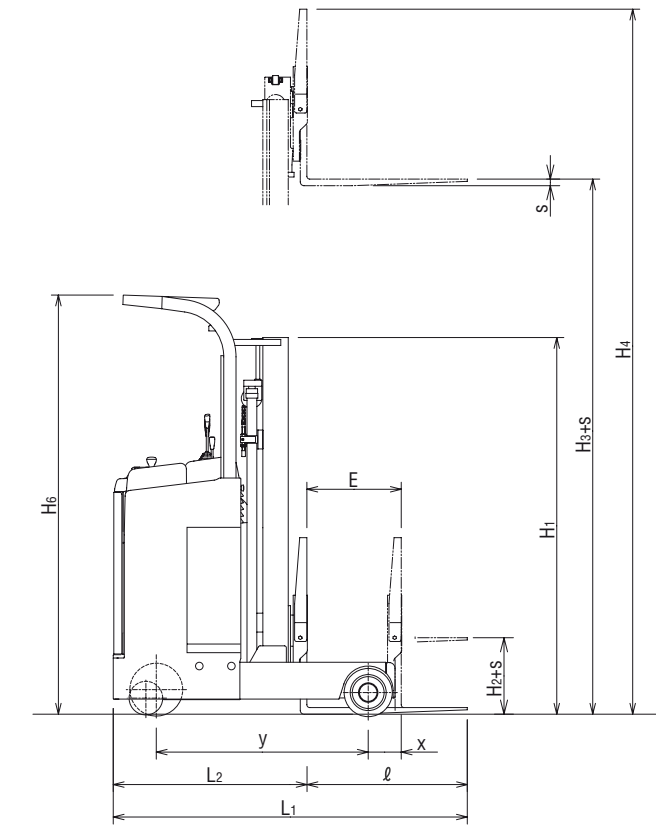

\* Included 200mm for clearance